

# MODEL 2900s - Downflow & Upflow

## *Service Manual*



**IMPORTANT:** Fill in pertinent information on page 4 for future reference.



# MODEL 2900s

## *Table of Contents*

Job Specification Sheet .....	4
Installation Instructions .....	5
3200 Timer Setting Procedure .....	6
3210 Timer Settings .....	7
Regeneration Cycle Program Setting Procedure .....	8
3200 Timer Assembly .....	10
3210 Timer Assembly .....	12
Environmental Power Head .....	14
Lower Environmental Power Head .....	16
Designer Power Head .....	18
Lower Designer Power Head .....	20
Control Valve Body .....	22
1600 Brine System .....	24
1650 Brine System .....	25
1700 Brine System .....	26
1710 Brine System .....	28
Regulation Assembly 1600/1700 - Upflow .....	30
1600/1700 System Nozzle & Throat Chart .....	31
2" Brass Meter Assembly .....	32
2" Plastic Meter Assembly .....	33
2300 Safety Brine Valve .....	34
2310 Safety Brine Valve .....	35
2350 Safety Brine Valve .....	36
Service Valve Operator .....	37
Control Valve Side Mount Adapter .....	38
Service Assemblies .....	39
Service Instructions .....	40
Service/Backwash/Brine Positions (Downflow) .....	42
Slow Rinse/Rapid Rinse/Brink Tank Fill Positions (Downflow) .....	43
Service/Brine/Slow Rinse Positions (Upflow) .....	44
Back Wash/Rapid Rinse/Brink Tank Fill Positions (Upflow) .....	45
Tank with Pressure Regulator .....	46
Flow Data & Injector Draw Rates (Downflow) .....	47
Environmental Backplate Line Drawing/Distributor Cut Height .....	49
Designer Backplate Line Drawing .....	50
System #4 - Typical Single Tank Installation with Optional Meter .....	51
System #5 - Interlock - Typical Twin Tank Installation with Optional Meter Interlock and No Hard Water Bypass .....	52
System #6 - Twin Series Regeneration System #7 - Twin Alternator Installation .....	53
System #4 - Single Valve Regeneration Immediate and Delayed Valve Wiring .....	54
System #4 - With Remote Signal Start Valve Wiring .....	55
System #5 - Interlocked Regeneration Valve Wiring .....	56
System #6 - Series Regeneration Valve Wiring .....	57
System #7 - Alternating Regeneration Valve Wiring .....	58
System #7 - Alternating Regeneration Multi-Valve System Valve Wiring .....	59

**IMPORTANT:** The information, specifications and illustrations in this manual are based on the latest information available at the time of printing. The manufacturer reserves the right to make changes at any time without notice.

# MODEL 2900s

---

---

## Job Specification Sheet

---

- JOB NO. \_\_\_\_\_
  - MODEL NO. \_\_\_\_\_
  - WATER TEST \_\_\_\_\_
  - CAPACITY PER UNIT \_\_\_\_\_ MAX. \_\_\_\_\_ PER REGENERATION
  - MINERAL TANK SIZE DIA. \_\_\_\_\_ HEIGHT \_\_\_\_\_
  - BRINE TANK SIZE & SALT SETTING PER REGENERATION:  
\_\_\_\_\_
- 
- 2900 CONTROL VALVE SPECIFICATIONS
    - 1) Type of Timer (see pages 10-13)
      - A) 7 day or 12 day
      - B) \* 1,250 to 21,250 gallon meter or  
\* 6,250 to 106,250 gallon meter  
\* Other \_\_\_\_\_
      - C) Meter Wiring Package
        - 1) System #4 - 1 tank; 1 meter; immediate or delayed regeneration
        - 2) System #5 - 2 tanks; 2 meters; interlock
        - 3) System #6 - 2 tanks; 1 meter; series regeneration
        - 4) System #7 - 2 tanks; 1 meter; alternator
    - 2) Timer Program Settings (see pages 6-9)
      - A) Backwash \_\_\_\_\_ min.
      - B) Brine & Slow Rinse \_\_\_\_\_ min.
      - C) Rapid Rinse \_\_\_\_\_ min.
      - D) Brine Tank Refill \_\_\_\_\_ min.
    - 3) Drain Line Flow Controller \_\_\_\_\_
    - 4) Brine Line Flow Controller \_\_\_\_\_
    - 5) Injector Size # \_\_\_\_\_
    - 6)
      - A) Hard Water By-Pass
      - B) No Hard Water By-Pass

---

## *General Commercial Pre-Installation Check List*

---

**WATER PRESSURE:** A minimum of 20 pounds of water pressure is required for regeneration valve to operate effectively.

**ELECTRICAL FACILITIES:** A continuous 110 volt, 60 Hertz current supply is required. Make certain the current supply is always hot and cannot be turned off with another switch.

**EXISTING PLUMBING:** Condition of existing plumbing should be free from lime and iron buildup. Piping that is built up heavily with lime and/or iron should be replaced. If piping is clogged with iron, a separate iron filter unit should be installed ahead of the water softener.

**LOCATION OF SOFTENER AND DRAIN:** The softener should be located close to a drain.

**BY-PASS VALVES:** Always provide for the installation of a by-pass valve.

**CAUTION:** Water pressure is not to exceed 120 p.s.i., water temperature is not to exceed 100° F, and the unit cannot be subjected to freezing conditions.

---

## *Installation Instructions*

---

1. Place the softener tank where you want to install the unit making sure the unit is level and on a firm base.
2. All plumbing should be done in accordance with local plumbing codes. The pipe size for the drain line should be the same size as the drain line flow control female connection. Water meters are to be installed on soft water outlets. Twin units with (1) one meter shall be installed on common soft water outlet of units.
3. Solder joints near the drain must be done prior to connecting the Drain Line Flow Control fitting. Leave at least 6" between the DLFC and solder joints when soldering when the pipes are connected on the DLFC. Failure to do this could cause interior damage to the DLFC.
4. Teflon tape is the only sealant to be used on the drain fitting. The drain from twin units may be run through a common line.
5. Make sure that the floor is clean beneath the salt storage tank and that it is level.
6. Place approximately 1" of water above the grid plate (if used) in your salt tank. Salt may be placed in the unit at this time.
7. On units with a by-pass, place in by-pass position. Turn on the main water supply. Open a cold soft water tap nearby and let run a few minutes or until the system is free from foreign material (usually solder) that may have resulted from the installation.
8. Place the by-pass in service position.
9. Manually index the softener control into "service" position and let water flow into the mineral tank. When water flow stops, open a cold water tap nearby and let run until air pressure is relieved.
10. Electrical: All electrical connections must be connected according to codes. Use electrical conduit if applicable. Remote meter systems and Twin meter system wiring diagrams can be found at the back of the service manual.
11. Plug into power supply.

# MODEL 2900s

## 3200 Timer Setting Procedure

### How To Set Days On Which Water Conditioner Is To Regenerate:

Rotate the skipper wheel until the number "1" is at the red pointer. Set the days that regeneration is to occur by sliding tabs on the skipper wheel outward to expose trip fingers. Each tab is one day. Finger at red pointer is tonight. Moving clockwise from the red pointer, extend or retract fingers to obtain the desired regeneration schedule.

### How To Set The Time Of Day:

Press and hold the red button in to disengage the drive gear.

Turn the large gear until the actual time of day is at the time of day pointer.

Release the red button to again engage the drive gear.

### How To Manually Regenerate Your Water Conditioner At Any Time:

Turn the manual regeneration knob clockwise.

This slight movement of the manual regeneration knob engages the program wheel and starts the regeneration program.

The black center knob will make one revolution in the following approximately three hours and stop in the position shown in the drawing.

Even though it takes three hours for this center knob to complete one revolution, the regeneration cycle of your unit might be set only one half of this time.

In any event, conditioned water may be drawn after rinse water stops flowing from the water conditioner drain line.

### How to Adjust Regeneration Time:

1. Disconnect the power source.
2. Locate the three screws behind the manual regeneration knob by pushing the red button in and rotating the 24 hour dial until each screw appears in the cut out portion of the manual regeneration knob.
3. Loosen each screw slightly to release the pressure on the time plate from the 24 hour gear.
4. Locate the regeneration time pointer on the inside of the 24 hour dial in the cut out.
5. Turn the time plate so the desired regeneration time aligns next to the raised arrow.
6. Push the red button in and rotate the 24 hour dial. Tighten each of the three screws.
7. Push the red button and locate the pointer one more time to ensure the desired regeneration time is correct.
8. Reset the time of day and restore power to the unit.

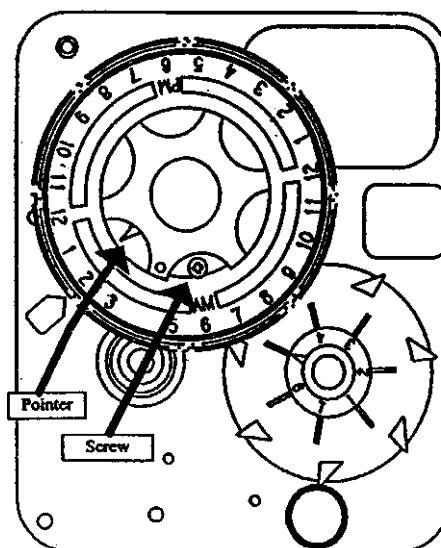
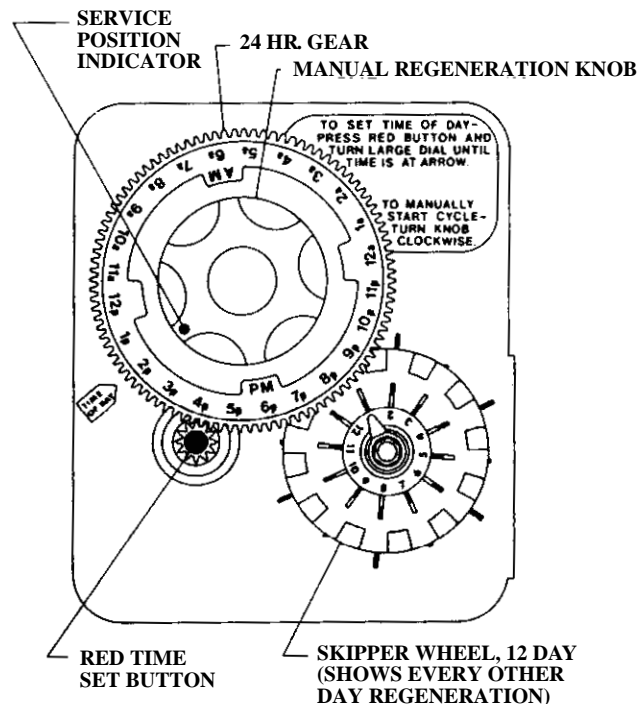

3200 ADJUSTABLE REGENERATION TIMER

### Typical Programming Procedure

Calculate the gallon capacity of the system, subtract the necessary reserve requirement and set the gallons available opposite the small white dot on the program wheel gear. Note, drawing shows 8,750 gallon setting. The capacity (gallons) arrow denotes remaining gallons exclusive of fixed reserve.

### How To Set The Time Of Day:

Press and hold the red button in to disengage the drive gear.

Turn the large gear until the actual time of day is opposite the time of day pointer.

Release the red button to again engage the drive gear.

### How To Manually Regenerate Your Water Conditioner At Any Time:

Turn the manual regeneration knob clockwise.

This slight movement of the manual regeneration knob engages the program wheel and starts the regeneration program.

The black center knob will make one revolution in the following approximately three hours and stop in the position shown in the drawing.

Even though it takes three hours for this center knob to complete one revolution, the regeneration cycle of your unit might be set for only one half of this time.

In any event, conditioned water may be drawn after rinse water stops flowing from the water conditioner drain line.

### Immediate Regeneration Timers:

These timers do not have a 24 hour gear. Setting the gallons on the program wheel and manual regeneration procedure are the same as previous instructions.

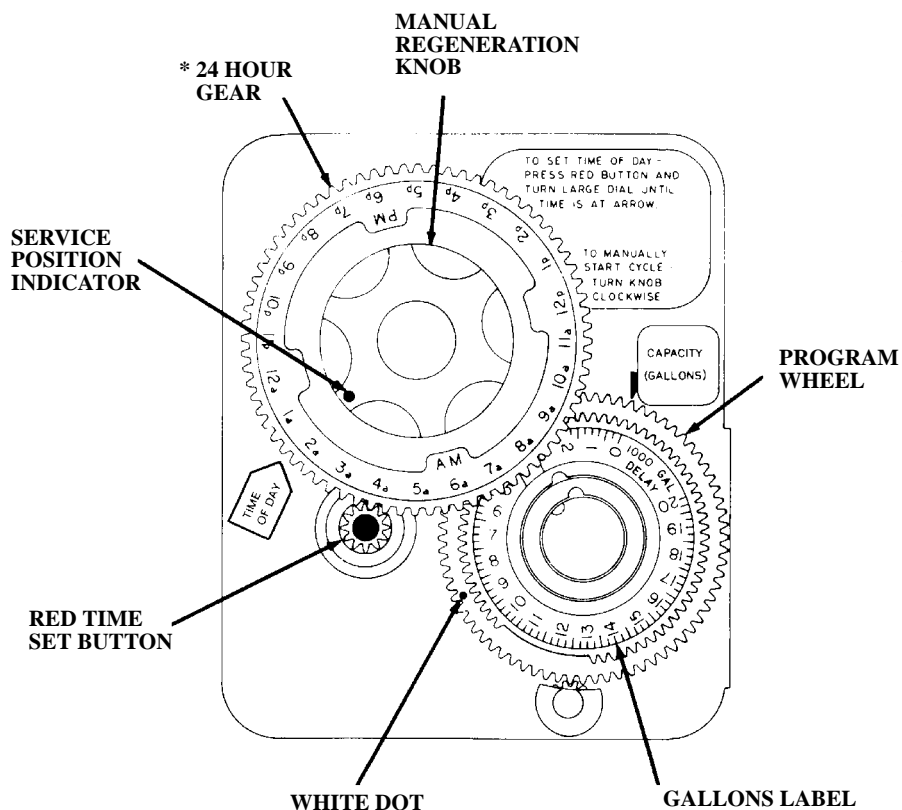

### NOTE:

To set meter capacity rotate manual knob one - 360° revolution to set gallonage.

\* Immediate regeneration timers do not have 24 hour gear. No time of day can be set.

# MODEL 3200 & 3210 TIMER SERIES

## Regeneration Cycle Program Setting Procedure - Downflow

### (Brine Tank Refill Separate From Rapid Rinse)

#### How To Set The Regeneration Cycle Program:

The regeneration cycle program on your water conditioner has been factory preset, however, portions of the cycle or program may be lengthened or shortened in time to suit local conditions.

#### 3200 & 3210 Series Timers (Figure to Right)

To expose cycle program wheel, grasp timer in upper left-hand corner and pull, releasing snap retainer and swinging timer to the right

To change the regeneration cycle program, the program wheel must be removed. Grasp program wheel and squeeze protruding lugs toward center, lift program wheel off timer. (Switch arms may require movement to facilitate removal.)

Return timer to closed position engaging snap retainer in back plate. Make certain all electrical wires locate above snap retainer post

#### Timer Setting Procedure for 3200 & 3210 Timer

##### How To Change The Length Of The Backwash Time:

The program wheel as shown in the drawing is in the service position. As you look at the numbered side of the program wheel, the group of pins starting at zero determines the length of time your unit will backwash.

FOR EXAMPLE: If there are six pins in this section, the time of backwash will be 12 min. (2 min. per pin). To change the length of backwash time, add or remove pins as required. The number of pins times two equals the backwash time in minutes.

##### How To Change The Length Of Brine And Rinse Time:

The group of holes between the last pin in the backwash section and the second group of pins determines the length of time that your unit will brine and rinse (2 min. per hole.)

To change the length of brine and rinse time, move the rapid rinse group of pins to give more or fewer holes in the brine and rinse section. Number of holes times two equals brine and rinse time in minutes.

##### How To Change The Length Of Rapid Rinse:

The second group of pins on the program wheel determines the length of time that your water conditioner will rapid rinse. (2 min. per pin.)

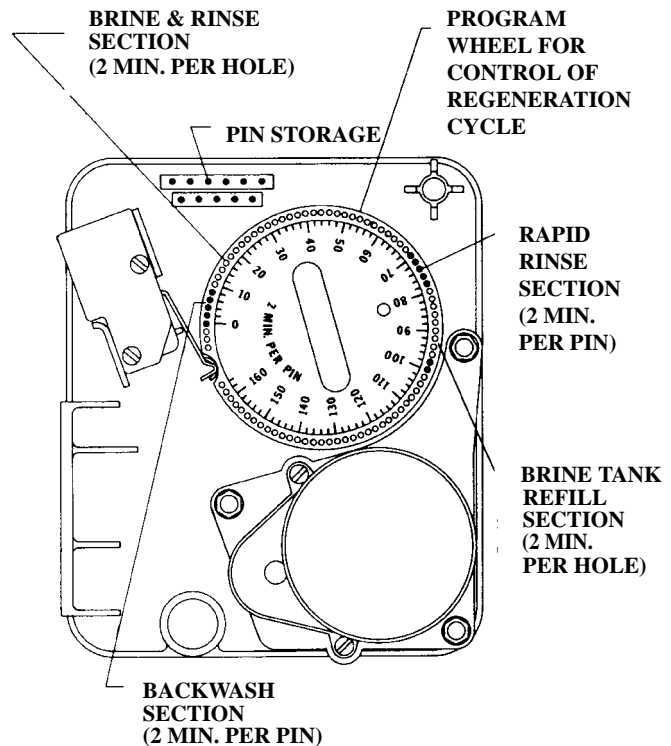

To change the length of rapid rinse time, add or remove pins at the higher numbered end of this section as required. The number of pins times two equals the rapid rinse time in minutes.

##### How To Change The Length Of Brine Tank Refill Time:

The second group of holes in the program wheel determines the length of time that your water conditioner will refill the brine tank (2 min. per hole.)

To change the length of refill time, move the two pins at the end of the second group of holes as required.

The regeneration cycle is complete when the outer microswitch is tripped by the two pin set at end of the brine tank refill section.

The program wheel, however, will continue to rotate until the inner micro-switch drops into the notch on the program wheel.

# MODEL 3200 & 3210 TIMER SERIES

## Regenerating Cycle Program Setting Procedure - Upflow

### (Brine Draw First)

#### How To Set The Regeneration Cycle Program:

The regeneration cycle program on your water conditioner has been factory preset, however, portions of the cycle or program may be lengthened or shortened in time to suit local conditions.

#### 3200 & 3210 Series Timers (Figure to Right)

To expose cycle program wheel, grasp timer in upper left-hand corner and pull, releasing snap retainer and swinging timer to the right

To change the regeneration cycle program, the program wheel must be removed. Grasp program wheel and squeeze protruding lugs toward center, lift program wheel off timer. (Switch arms may require movement to facilitate removal.)

Return timer to closed position engaging snap retainer in back plate. Make certain all electrical wires locate above snap retainer post

#### Timer Setting Procedure for 3200 & 3210 Timer

##### How To Change The Length Of The Backwash Time:

The program wheel as shown in the drawing is in the service position. As you look at the numbered side of the program wheel, the group of pins starting at zero determines the length of time your unit will backwash.

FOR EXAMPLE: If there are six pins in this section, the time of backwash will be 12 min. (2 min. per pin). To change the length of backwash time, add or remove pins as required. The number of pins times two equals the backwash time in minutes.

##### How To Change The Length Of Brine And Rinse Time:

The group of holes between the last pin in the backwash section and the second group of pins determines the length of time that your unit will brine and rinse (2 min. per hole.)

To change the length of brine and rinse time, move the rapid rinse group of pins to give more or fewer holes in the brine and rinse section. Number of holes times two equals brine and rinse time in minutes.

##### How To Change The Length Of Rapid Rinse:

The second group of pins on the program wheel determines the length of time that your water conditioner will rapid rinse. (2 min. per pin.)

To change the length of rapid rinse time, add or remove pins at the higher numbered end of this section as required. The number of pins times two equals the rapid rinse time in minutes.

##### How To Change The Length Of Brine Tank Refill Time:

The second group of holes in the program wheel determines the length of time that your water conditioner will refill the brine tank (2 min. per hole.)

To change the length of refill time, move the two pins at the end of the second group of holes as required.

The regeneration cycle is complete when the outer microswitch is tripped by the two pin set at end of the brine tank refill section. The program wheel, however, will continue to rotate until the inner micro-switch drops into the notch on the program wheel.

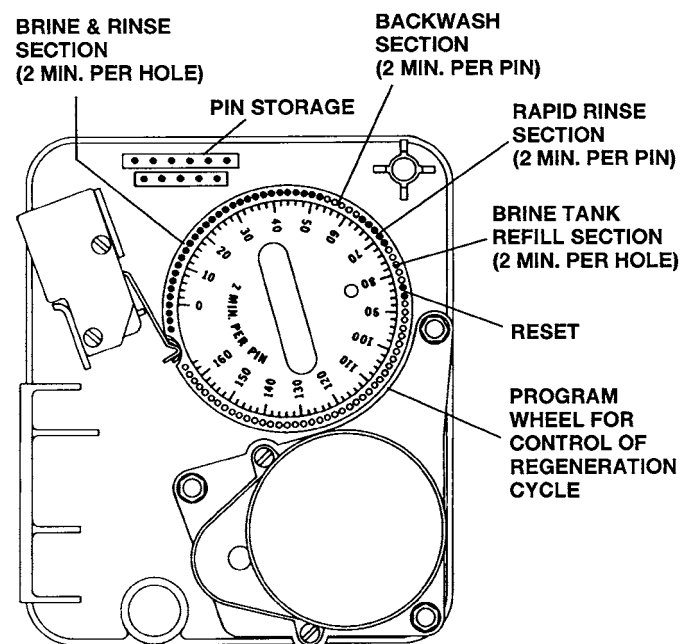

# MODEL 2900s

## 3200 Timer Assembly

(See opposite page for parts list)

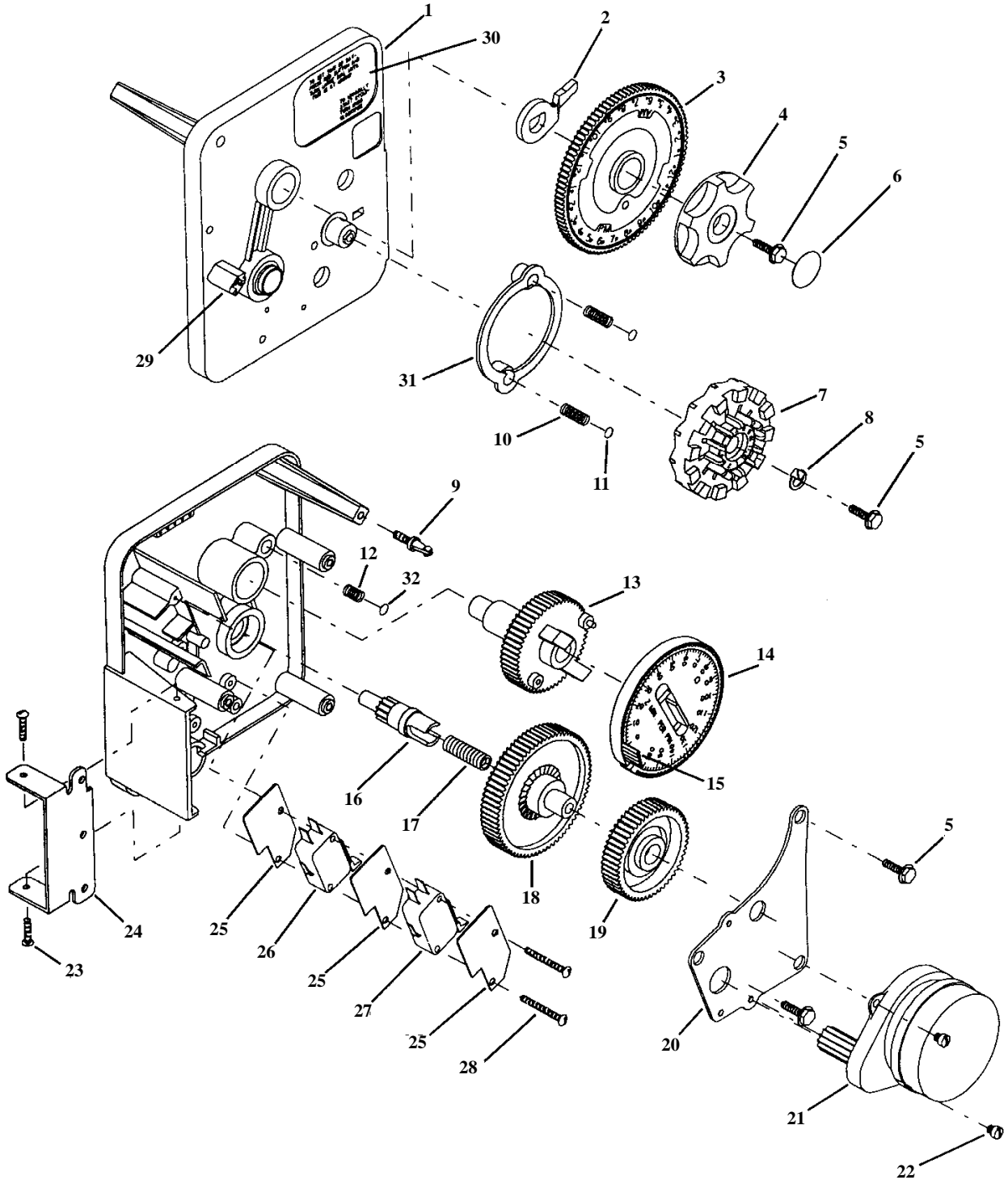

# MODEL 2900s

## 3200 Timer Assembly

### Parts List

Item No.	Quantity	Part No.	Description
1	1	13870	Housing, Timer, 3200
2	1	13011	Arm, Cycle Actuator
3	1	40096-24	Dial 12AM Regen Assy, Black
		40096-02	Dial 2AM Regen Assy, Black
4	1	13886	Knob, 3200
5	5	13296	Screw, Hex Wsh, 6-20 x 1/2 Type 25 Steel Zinc
6	1	11999	Label, Button
7	1	14381	Skipper Wheel Assy, 12 Day
		14860	Skipper Wheel Assy, 7 Day
8	1	13014	Pointer, Regeneration
9	1	14265	Clip, Spring
10	2	13311	Spring, Detent, Timer
11	2	13300	Ball, 1/4" SS
12	1	15424	Spring, Detent, Timer
13	1	13911	Gear, Main Drive, Timer
14	1	19210	Program Wheel Assy, 3200
15	21	15493	Pin, Spring, 1/16 x 5/8 SS
16	1	13018	Pinion, Idler
17	1	13312	Spring, Idler Shaft
18	1	13017	Gear, Idler
19	1	13164	Gear, Drive
20	1	13887	Plate, Motor Mounting
21	1	18743-1	Motor, 120V, 60Hz 1/30 RPM, 5600
		19659-1	Motor, 24V, 60 Hz 1/30 RPM
22	2	13278	Screw, Phil Hd Mach, 6-32 x 1/8 Steel Zinc
23	3	11384	Screw, Phil, 6-32 x 1/4 Zinc
24	1	13881	Bracket, Hinge Timer
25	3	14087	Insulator
26	1	10896	Switch, Micro
27	1	15320	Switch, Micro, Timer
28	2	11413	Screw, Pan Hd Mach, 4-40 x 1 1/8 MS Steel Zinc
29	1	14007	Label, Time of Day
30	1	14045	Label, Instruction
31	1	13864	Ring, Skipper Wheel
32	1	15066	Ball, 1/4" Delrin
Not Shown	1	13902	Harness, 3200
Not Shown	2	40422	Nut, Wire, Tan
Not Shown	1	15354-01	Wire, Ground 4"

# MODEL 2900s

## 3210 Timer Assembly

(See opposite page for parts list)

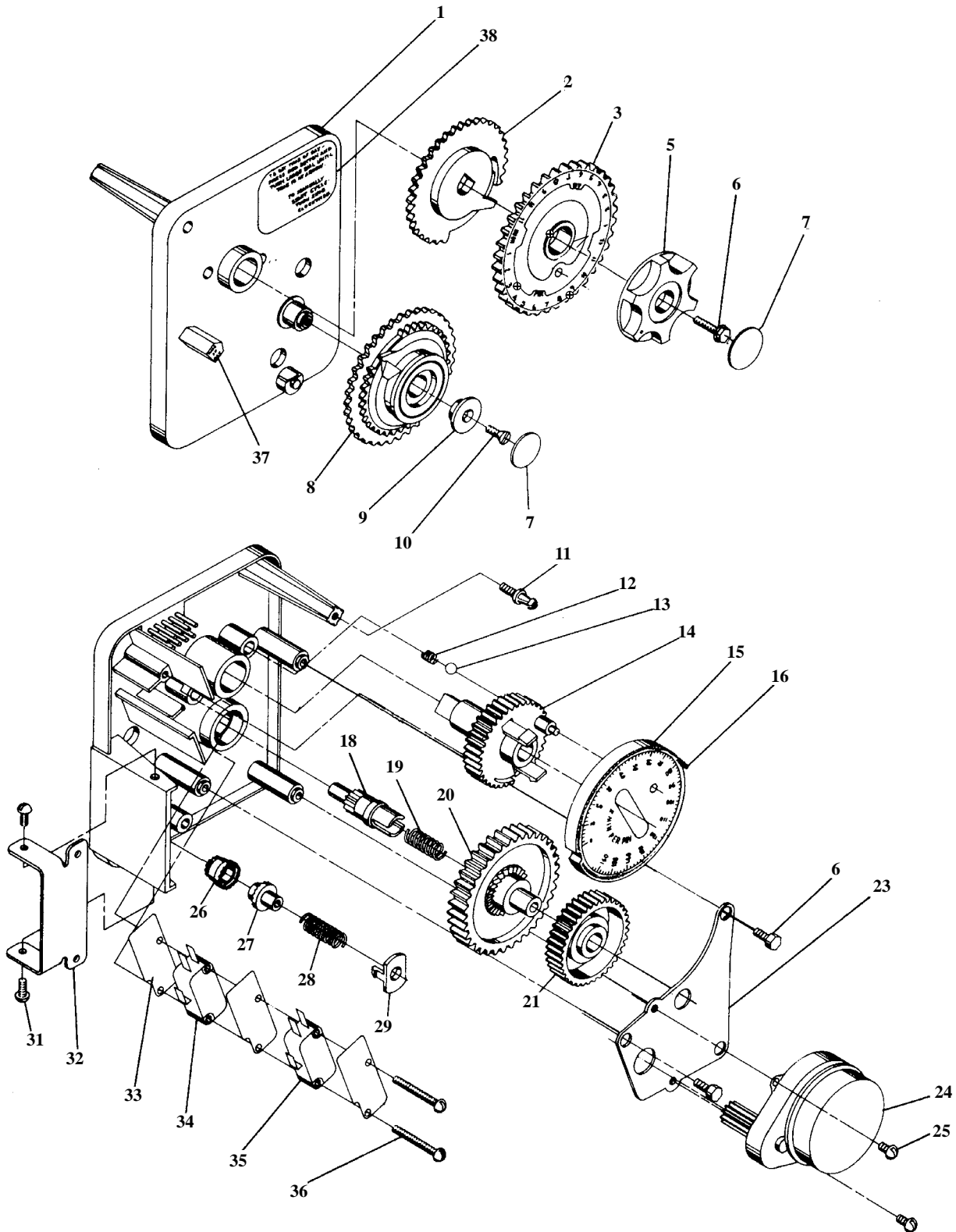

# MODEL 2900s

## 3210 Timer Assembly

### Parts List

Item No.	Quantity	Part No.	Description
1	1	13870-01	Housing Assy, Timer, 3210
2	1	13802	Gear, Cycle Actuator
3	1	40096-24	Dial 12 AM Regen Assy, Black
		40096-02	Dial 2 AM Regen Assy, Black
5	1	13886	Knob, 3200
6	4	13296	Screw, Hex Wsh, 6-20 x 1/2 Type 25 Steel Zinc
7	2	11999	Label, Button
8	1	60405-50	Program Wheel, w/2" Std Label
9	1	13806	Retainer, Program Wheel
10	1	13748	Screw, Flt Hd St, 6-20 x 1/2 Type 25 316 S.S.
11	1	14265	Clip, Spring
12	1	15424	Spring, Detent, Timer
13	1	15066	Ball, 1/4" Delrin
14	1	13911	Gear, Main Drive, Timer
15	1	19210	Program Wheel Assy, 3200
16	21	15493	Pin, Spring, 1/16 x 5/8 SS
17			Not Assigned
18	1	13018	Pinion, Idler
19	1	13312	Spring, Idler Shaft
20	1	13017	Gear, Idler
21	1	13164	Gear, Drive
23	1	13887	Plate, Motor Mounting
24	1	18743	Motor, 120V, 60 Hz 1/30 RPM, 5600
		19659-1	Motor, 24V, 60 Hz 1/30 RPM
25	2	13278	Screw, Phil Hd Mach, 6-32 x 1/8 Steel Zinc
26	1	13830	Pinion, Program Wheel Drive
27	1	13831	Clutch, Drive Pinion
28	1	14276	Spring, Meter Clutch
29	1	14253	Retainer, Clutch Spring
30			Not Assigned
31	3	11384	Screw, Phil, 6-32 x 1/4 Zinc Rolling Screw
32	1	13881	Bracket, Hinge Timer
33	3	14087	Insulator
34	1	10896	Switch, Micro
35	1	15320	Switch, Micro, Timer
36	2	11413	Screw, Pan Hd Mach, 4-40 x 1 1/8 MS Steel Zinc
37	1	14007	Label, Time of Day
38	1	14045	Label, Instruction
39	1	13902	Harness, 3200 - Not Shown
41	1	15354-01	Wire, Ground 4" - Not Shown
42	1	15465	Label, Caution - Not Shown
43	1	14198	Label, Indicator - Not Shown

# MODEL 2900s

## Environmental Power Head

(See opposite page for parts list)

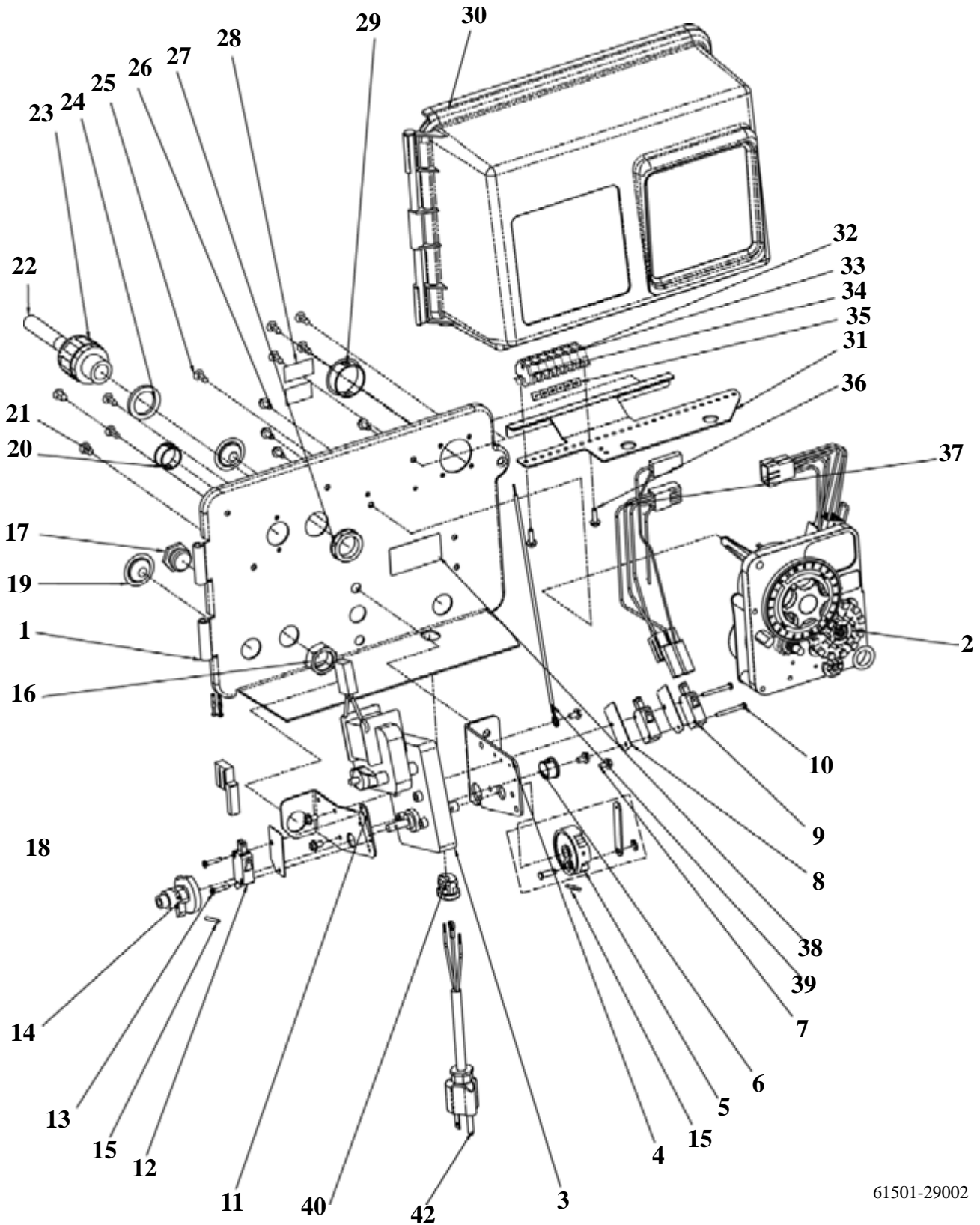

61501-29002

# MODEL 2900s

## Environmental Power Head

### Parts List

Item No.	Quantity	Part No.	Description
1	1	18697-15	Backplate, Hinged
2	1	3200 Clock Timer Assy	3200 Clock Timer Assy
	1	3200 Meter Timer Assy	3200 Meter Timer Assy
3	1	40384	Motor, Drive, 115V, 60 Hz, SP, Fam 1
		40385	Motor, Drive, 24V, 50/60 Hz, SP Fam 1
		40386	Motor, Drive, 220V, 50/60 Hz, Sp Fam 1
4	1	10774	Bracket, Motor Mounting
5	1	60160-10	Drive Cam Assy, STF, Black
		<b>60160-30</b>	<b>Drive Cam Assy, Upflow</b>
		<b>60160-31</b>	<b>Drive Cam Assy, Upflow, Variable</b>
6	1	17904	Bushing, Heyco 1/2, Heyco #2073
7	5	10872	Screw, Hex Wsh, 8-32 X 17/64 18-8 S.S.
8	3	10302	Insulator, Limit Switch
9	2	10218	Switch, Micro
10	2	14923	Screw, Pan Hd Mach, 4-40 X 1 MS Steel Zinc
11	1	11826-02	Bracket, Motor, Aux Switch Brine Valve Side
12	1	10896	Switch, Micro
13	2	11805	Screw, Rd Hd, 4-40 X 5/8 Type 1 Steel Zinc
14	1	12472	Cam Assy, Tri-Stack, After RR
		12777	Cam, Shut-Off Valve
		15770	Cam Assy, Special Tri-Stack, After Brine Fill
		15805	Cam, SVO
		<b>19887</b>	<b>Cam, Brine, 2750 U/F, Std</b>
		<b>19749</b>	<b>Cam, Brine, 2750, U/F, Variable</b>
15	2	10338	Pin, Roll 3/32 x 7/8
16	1	10269	Nut, Jam, 3/4-16
17	1	10712	Fitting, Brine Valve
18	1	14822	Harness, 2900
19	2	19691	Plug, .750 Dia Recessed, Black
20	1	15806	Plug Hole, Heyco #2693
21	1	19801	Plug, .190 Dia, White Heyco 0307
22	1	18693	Conduit, Interdrive
23	1	18691-01	Fitting, Conduit
24	1	18692	Washer, 3/8", Sealing
25	7	19800	Plug, .140 Dia, White Heyco 0304
26	4	10300	Screw, Slot Hex Wsh, 8-18 X 3/8 Type "B" RC 44-47
27	1	18691-02	Nut, Conduit Fitting 1/2"
28	1	40038-03	Label, Voltage, 120V, 3200ET
29	1	17421	Plug, 1.20 Hole Heyco #2733
30	1	60219-02	Cover Assy, Environmental, Black W/Clear Window
31	1	19772	Bracket, Terminal Block
32	1	40174	Terminal Block, Green/Yellow commercial, 809-260/141
33	6	41084	Terminal Block, Segment, Gray
34	1	41085	Endplate, Terminal Block, Gray
35	2	15250	Label, Terminal Strip
36	2	13296	Screw, Hex Wsh, 6-20 6-20 x 1/2 Type 25 Steel Zinc
37	1	40400	Harness, Drive, Designer/Environmental
38	1	40370	Label, Serial Number, with Bar Code
39	1	40175-01	Wire, Ground, Commercial Valves
40	1	13547	Strain Relief, Flat Cord Heyco #30-1
		13547-01	Strain Relief, Euro Round Cord
		13547-02	Strain Relief, U.S. Round
		14924	Strain Relief, Heyco #1247
41	1	17967 (Not Shown)	Fitting Assy, Liquid-Tight, Black
42	1	11545	Powercord, 4' European, Black
		19303	Powercord, 8', Australian
		19885	Powercord, Japanese, 110V/120V
		40084-12	Powercord, 12' US, Round, 120V, Sys 5, 6, 7 & 2900/3150/3900
		40085-12	Powercord, 12' US, Round, 240V

# MODEL 2900s

## *Lower Environmental Power Head*

*(See opposite page for parts list)*

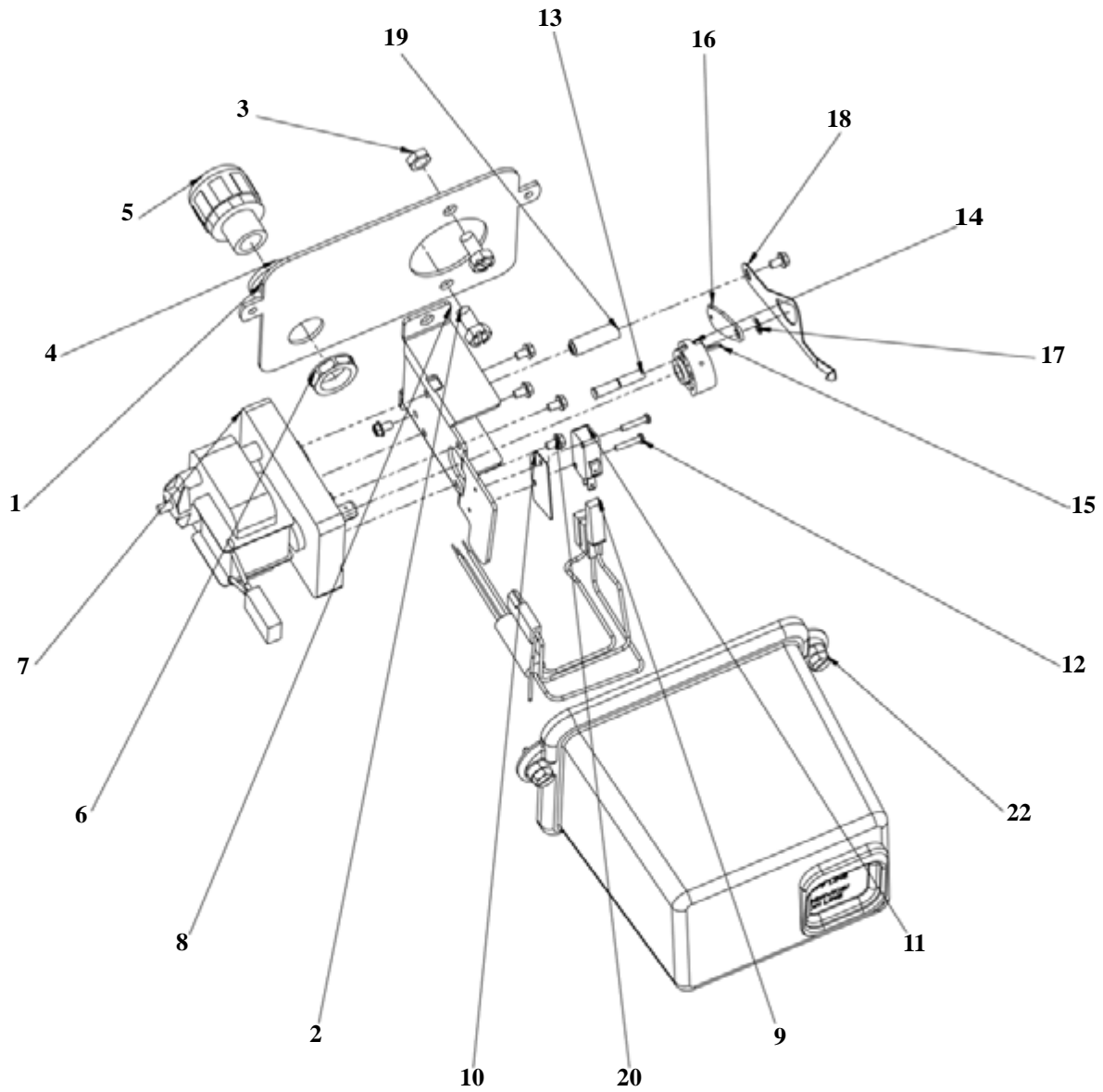

61501-29003

# MODEL 2900s

## Lower Environmental Power Head

### Parts List

Item No.	Quantity	Part No.	Description
1.....	1.....	18709.....	Backplate, Lower
2.....	2.....	11224.....	Screw, Hex Hd, 5/16 - 18 x 5/8
3.....	2.....	16346.....	Nut, Hex, Jam, 5/16-18, 18-8 S.S.
4.....	1.....	18692.....	Washer, 3/8, Sealing
5.....	1.....	18691-01.....	Fitting, Conduit
6.....	1.....	18691-02.....	Nut, Conduit Fitting, 1/2"
7.....	1.....	40387.....	Motor, Drive, 115v, 60 Hz, SP, Fam 2
7.....	1.....	40388.....	Motor, Drive, 24V, 50/60 Hz, SP, Fam 2
7.....	1.....	40389.....	Motor, Drive, 220V, 50/60 Hz, SP, Fam 2
8.....	1.....	14769.....	Bracket, Motor, 2900
9.....	1.....	40405.....	Harness, Lower Drive, Sys4, Env
10.....	1.....	10302.....	Insulator, Limit Switch
11.....	1.....	10218.....	Switch, Micro
12.....	2.....	19849.....	Screw, Pan Hd, 4-40 X 5/8
13.....	1.....	18746.....	Bearing, Connecting Rod
14.....	1.....	14775.....	Cam, Drive, 2900
15.....	1.....	41022.....	Pin, Roll, 2900 Lower
16.....	1.....	14759.....	Link, Piston Rod
17.....	1.....	10250.....	Ring, Retaining
18.....	1.....	18725.....	Indicator, Service/Standby
19.....	1.....	18726.....	Spacer, Indicator
20.....	6.....	10872.....	Screw, Hex Wsh, 8-32 X 17/64 18-8 S.S.
21.....	6.....	14044 (Not Shown)...	Tie, Cable, Heyco, Vnt#4-18
22.....	1.....	60217-02.....	Cover Assy, 2900, Lower, Black, Environmental

# MODEL 2900s

## Designer Power Head

(See opposite page for parts list)

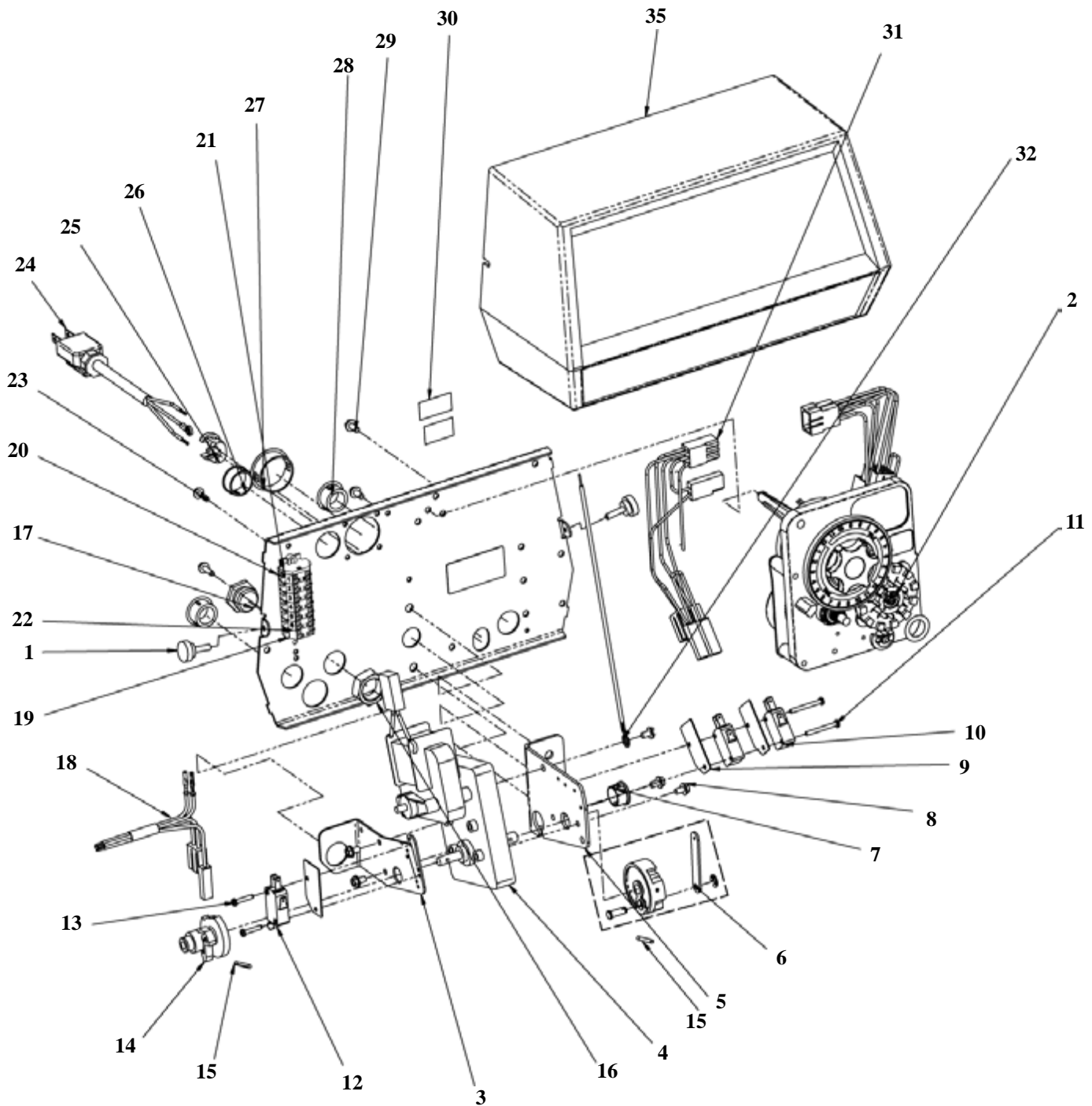

61501-29001

# MODEL 2900s

## Designer Power Head

### Parts List

Item No.	Quantity	Part No.	Description
1	1	40264	Backplate, SS/SVO, W/T-Screws, 2750,2850,2900
2	1	3200 Meter Timer Assy	3200 Meter Timer Assy
2	-	3200 Clock Timer Assy	3200 Clock Timer Assy
3	1	11826-02	Bracket, Motor, Aux Switch Brine Valve Side
4	1	40384	Motor, Drive, 115V, 60HZ, SP, Fam 1
		40385	Motor, Drive, 24V, 50/60 Hz, SP Fam 1
		40386	Motor, Drive, 220V, 50/60 Hz, SP Fam 1
5	1	10774	Bracket, Motor Mounting
6	1	60160-20	Drive Cam Assy, Std
		<b>60160-30</b>	<b>Drive Cam Assy, Upflow</b>
		<b>60160-31</b>	<b>Drive Cam Assy, Upflow, Variable</b>
7	1	17904	Bushing Heyco 1/2, Heyco #2073
8	5	10872	Screw, Hex WSH, 8-32 X 17/64 18-8 S.S.
9	3	10302	Insulator, Limit Switch
10	2	10218	Switch, Micro
11	2	14923	Screw, Pan HD Mach, 4-40 X 1 MS Steel Zinc
12	1	10896	Switch, Micro
13	2	11805	Screw, RD HD, 4-40 X 5/8 Type 1 Steel Zinc
14	1	12472	Cam Assy, Tri-Stack, After RR
		12777	Cam, Shut-Off Valve
		15770	Cam Assy, Special Tri-Stack, After Brine Fill
		15805	Cam, SVO
		<b>19887</b>	<b>Cam, Brine, 2750 U/F Std</b>
15	1	10338	Pin, Roll, 3/32 x 7/8
16	1	10269	Nut, Jam, 3/4-16
17	1	10712	Fitting, Brine Valve
18	1	14822	Harness, 2900
19	1	40174	Terminal Block, Green/Yellow Commercial, 809-260/141
20	6	41084	Terminal Block, Segment, Gray
21	1	41085	Endplate, Terminal Block, Gray
22	2	15250	Label, Terminal Strip
23	2	13296	Screw, Hex WSH, 6-20 X 1/2 Type 25 Steel Zinc
24	1	11545	Power Cord, 4' European, Black
		19303	Power Cord, 8', Australian
		19885	Power Cord, Japanese, 110V/120V
		40084-12	Power Cord, 12' US, Round, 120V Sys 5, 6, 7
		40085-12	Power Cord, 12' US, Round, 240V
25	1	13547	Strain Relief, Flat Cord Heyco #30-1
		13547-01	Strain Relief, Euro Round Cord
		13547-02	Strain Relief, U.S. Round
		14924	Strain Relief, Heyco #1247
26	1	15806	Plug, Hole, Heyco #2693
27	1	17421	Plug, 1.20 Hole Heyco #2733
28	1	13741	Plug, 3/4", Knock-out, Heyco #2683
29	2	10300	Screw, Slot Hex Wsh, 8-18 X 3/8 Type "B" RC44-47
30	1	40038-03	Label, Voltage, 120V, 3200ET
31	1	14822	Harness, 2900
		16563	Harness, 2900/3900/Sys 7
		18585	Harness, 3900, Aux Switch
		40395	Harness, Drive, Sys#7, Multi
		40400	Harness, Drive, Designer/Environmental
32	1	40175-01	Wire, Ground, Commercial Valves
33	1	17967 (Not Shown)	Fitting Assy, Liquid-Tight, Black
34	1	15158 (Not Shown)	Tube, Cable Guide, 2900
35	1	19291-020	Cover, Designer

# MODEL 2900s

## Lower Designer Power Head

(See opposite page for parts list)

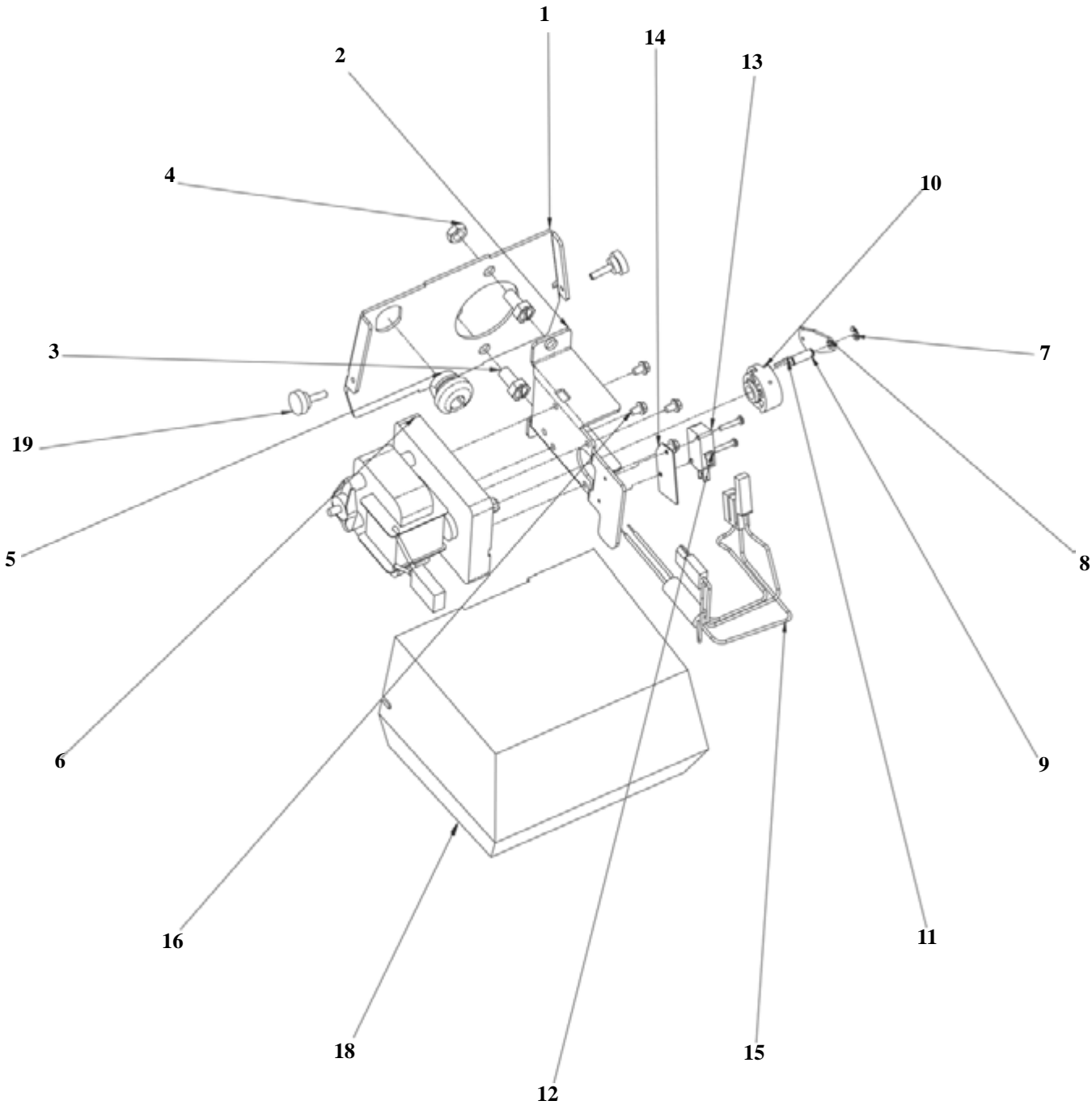

61501-29003

# MODEL 2900s

## Lower Designer Power Head

### Parts List

Item No.	Quantity	Part No.	Description
1	1	14770	Backplate, Lower 2900
2	1	14769	Bracket, Motor, 2900
3	2	11224	Screw Hex Hd, 5/16 - 18 x 5/8 MS 410 S.S.
4	2	16346	Nut, Hex, Jam, 5/16-18, 18-8 S.S.
5	1	14924	Strain Relief Heyco #1247
6	1	40387	Motor, Drive, 115V, 60HZ, SP Fam 2
		40388	Motor, Drive, 24V, 50/60 Hz, Sp Fam 2
		40389	Motor, Drive, 220V, 50/60 Hz, Sp Fam 2
7	1	10250	Ring, Retaining
8	1	14759	Link, Piston Rod
9	1	14784	Bearing Connecting Rod
10	1	14775	Cam, Drive, 2900
11	1	41022	Pin, Roll, 2900 Lower
12	2	19849	Screw, Pan Hd, 4-40 X 5/8
13	1	10218	Switch, Micro
14	1	10302	Insulator, Limit Switch
15	1	40402	Harness, Lead, Sys#4, Designer
16	4	10872	Screw, Hex Wsh, 8-32 X 17/64 18-8 S.S.
17	1	14044 (Not Shown)	Tie, Cable, Heyco, Vnt#4-18
18	1	14800-02	Cover, Dust, Lower, 2900, Black
19	2	19367	Screw, Designer Cover, Thumb 8-32 Black UV Stable

# MODEL 2900s

## Control Valve Body - Upflow & Downflow

(See opposite page for parts list)

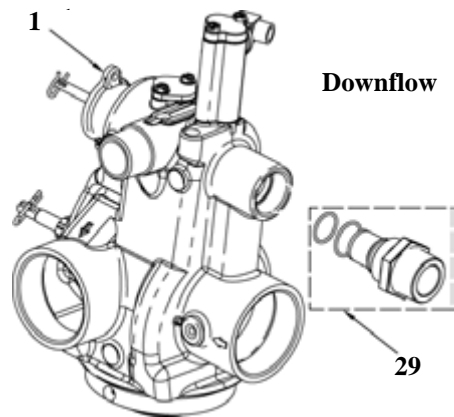
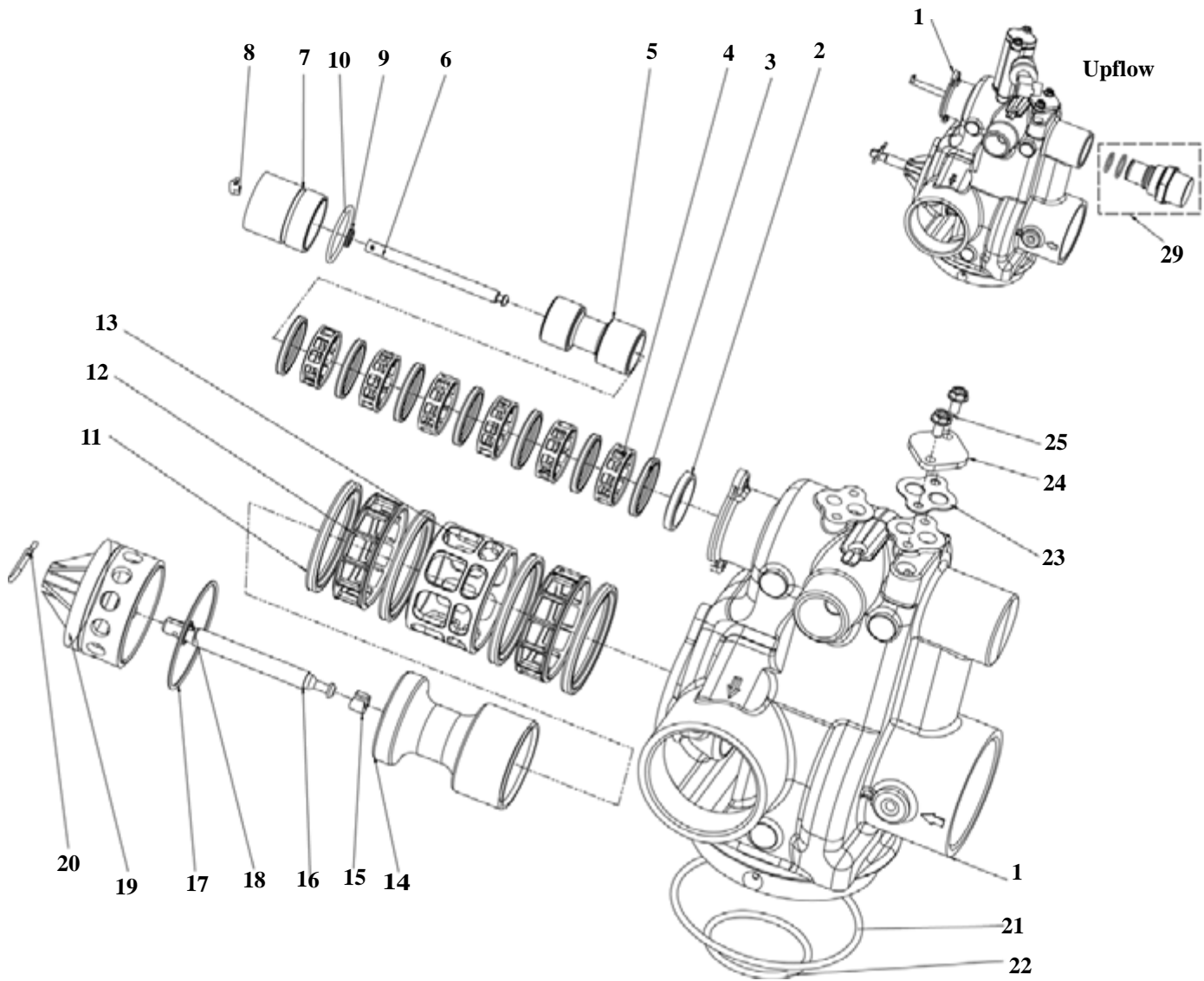

61500-290019454

## Control Valve Body - Upflow & Downflow

### Parts List

Item No.	Quantity	Part No.	Description
1.	1	41428.	Valve Body, 2900s, Machd, NPT U.S. Tap
		41428-xx	Valve Body, 2900s, Machined, W/Soft Water Adapt
2.	1	10757.	Spacer, End
		10757B	Spacer, End, Brass
3.	7	10545.	Seal, Piston
		10545-01	Seal, Piston, Viton
		10545-02	Seal, Piston, Silicone
4.	6	11451.	Spacer, 12 Hole
		16589.	Spacer, HW
5.	1	14451.	Piston, 2750
		<b>19454.</b>	<b>Piston, 2750, Upflow</b>
6.	1	41424.	Rod, Piston, 2900s, Upper
7.	1	41131.	Plug, End
8.	1	10909.	Pin, Link
9.	1	10209.	Quad Ring,-010
10	1	40078.	O-ring, 28mm X 2mm
11	1	11720.	Seal, Piston, 2900/3150
		10545-02	Seal, Piston, Silicone
12	4	10369.	Spacer, 2", 2900/3150
		14241-01	Spacer, Hot Water
13	2	14753.	Spacer, 2900
		16589.	Spacer, HW
14	1	14757.	Piston, HWBP
		14752.	Piston, 2900, NHWBP
15	1	14818.	Ring, Piston Rod, Snap
16	1	14758.	Rod, Piston, 2900
17	1	14922.	O-ring, -035, Piston
18	1	14926.	Quad Ring, -012
19	1	14754-00	End Plug Assy, 2900
		14754-10	End Plug Assy, 2900/2930, NHWBP
		19276-01	End Plug Assy, 2900s, Brass, HW
		41427-01	Plug, End, 2900s, Lower, White
		41427-11	Plug, End, 2900s, Lower, Black
20	1	14813.	Pin, Spring, Connecting Rod
21	1	13575.	O-ring, -240
		15210.	O-ring, -343, Park Tank
22	1	13577.	O-ring, -226
23	1	19925.	Gasket, Injector Body, 1700 Regulator
24	1	11893.	Cap, Injector, SS
25	2	15137.	Screw, Hex Wsh Mach, 10 - 24 x 3/8 MS 18-8 S.S.
29	1	61525.	Softwater Adapter Kit, 2900s

# MODEL 2900s

## 1600 Brine System

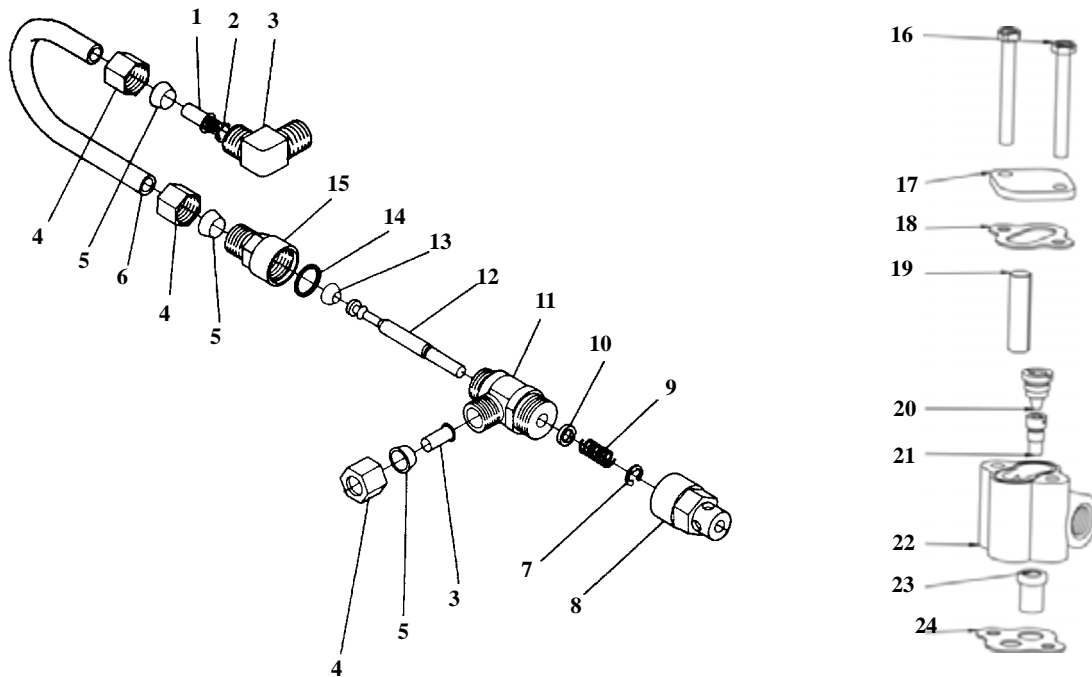

Item No.	Quantity	Part No.	Description
1	1	10328	Fitting, Elbow, 90 Deg. 1/4 PT x 3/8T
2	1	12767	Screen, Brine
3	2	10332	Fitting, Insert, 3/8
4	3	10329	Fitting, Tube, 3/8 Nut, Brass
5	3	10330	Fitting, Sleeve, 3/8 Celcon
6	1	16508	Tube, Brine, 1600, PVC
		16508-01	Tube, Brine Valve, 2850/1600
		<b>41683</b>	<b>Tube, Brine Valve, UF, 1600/1650</b>
7	1	10250	Ring, Retaining
8	1	11749	Guide, Brine Valve Stem
9	1	10249	Spring, Brine Valve
10	1	12550	Quad Ring, -009
11	1	12748	Brine Valve Body Assy, 1600 w/Quad Ring
12	1	12552	Brine Valve Stem, 1600
13	1	12626	Seat, Brine Valve
14	1	11982	O-Ring, -016
15	1	60020-25	BLFC, .25 GPM, 1600
		60020-50	BLFC, .50 GPM, 1600
		60020-100	BLFC, 1.0 GPM, 1600
16	2	10692	Screw, Slot Hex Hd, 10 - 24X 18-8 S.S.
17	1	11893	Cap, Injector, SS
18	1	10229	Gasket, Injector Cap, 1600
19	1	10227	Screen, Injector
20	1	10913	Nozzle, Injector
21	1	10914	Throat, Injector
22	1	17776	Body, Injector, 1600
23	1	16221	Disperser, Air
24	1	14805	Gasket, Injector Body, 1600/1700

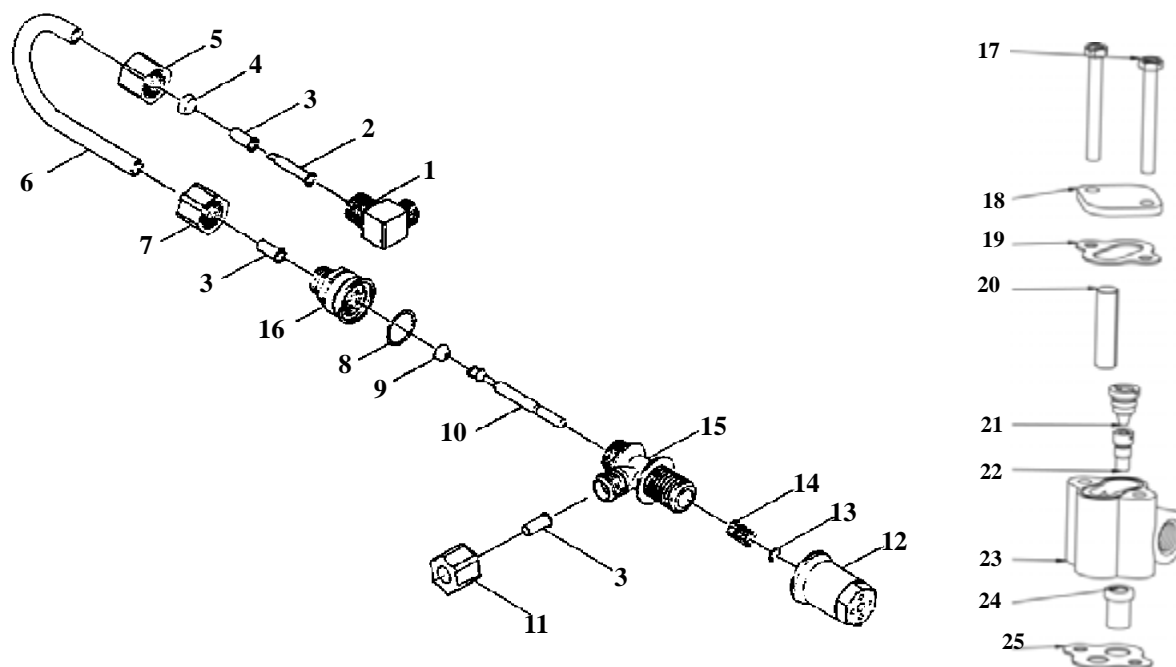

Item No.	Quantity	Part No.	Description
1	1	10328	Fitting, Elbow, 90 Deg 1/4 NPT x 3/8T
2	1	12767	Screen, Brine
3	3	10332	Fitting, Insert, 3/8
4	1	10330	Fitting, Sleeve, 3/8 Celcon
5	1	10329	Fitting, Tube, 3/8 Nut, Brass
6	1	16508	Tube, Brine, 1600, PVC
		<b>41683</b>	<b>Tube, Brine Valve, UF, 1600/1650</b>
7	1	19625	Nut Assy, 3/8", Plastic
8	1	16924	O-Ring, -018
9	1	12626	Seat, Brine Valve
10	1	12552	Brine Valve Stem, 1600
11	1	19625	Nut Assy, 3/8", Plastic
12	1	17906	Guide, Brine Valve Stem
13	1	10250	Ring, Retaining
14	1	10249	Spring, Brine Valve
15	1	17884	Brine Valve Body Assy, 1650
16	1	60020-25	BLFC, .25 GPM, 1600
		60020-50	BLFC, .50 GPM, 1600
		60020-100	BLFC, 1.0 GPM, 1600
17	2	10692	Screw, Slot Hex Hd, 10 - 24X 18-8 S.S.
18	1	11893	Cap, Injector, SS
19	1	10229	Gasket, Injector Cap, 1600
20	1	10227	Screen, Injector
21	1	10913	Nozzle, Injector
22	1	10914	Throat, Injector
23	1	17776	Body, Injector, 1600
24	1	16221	Disperser, Air
25	1	14805	Gasket, Injector Body, 1600/1700

# MODEL 2900s

## 1700 Brine System

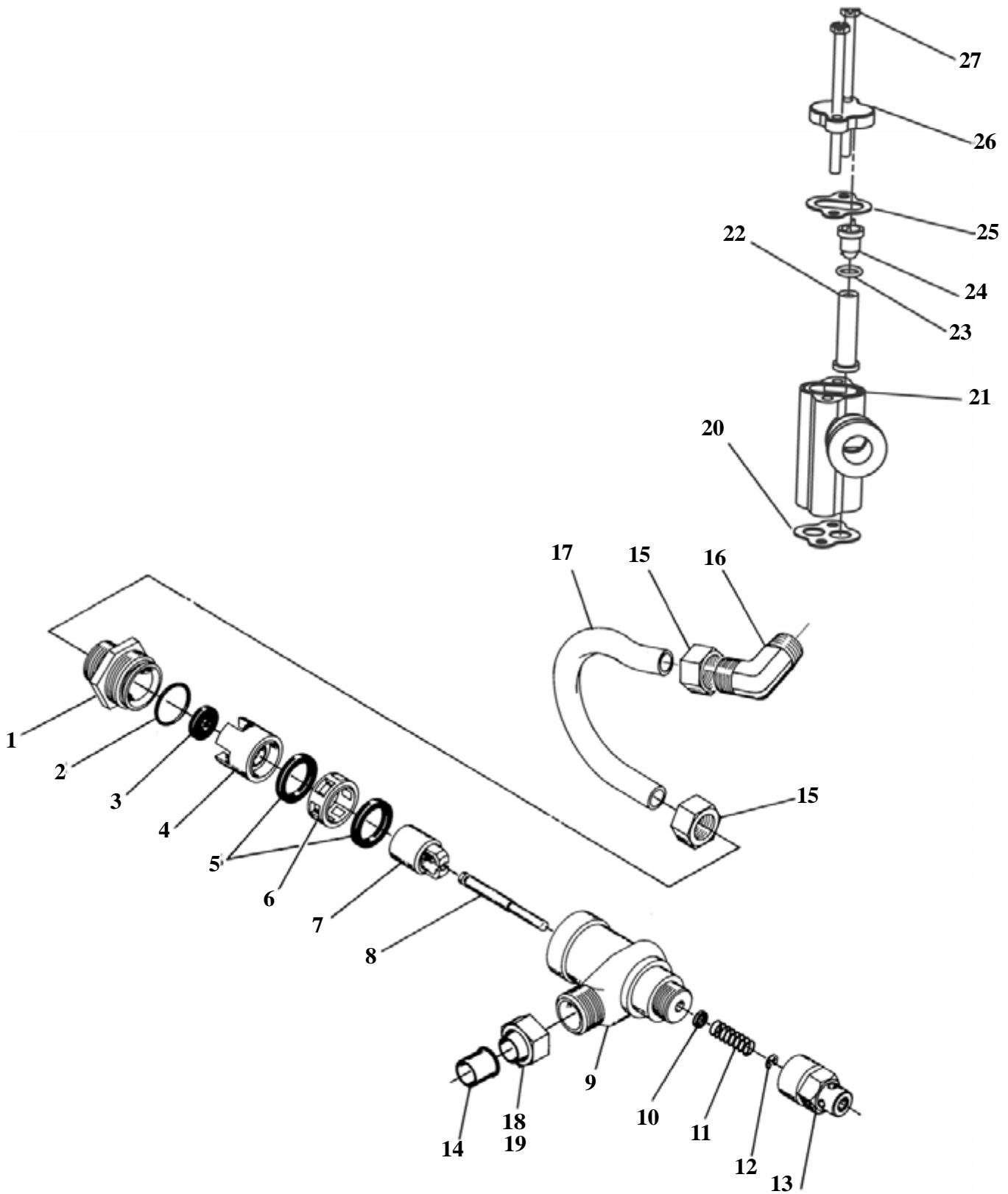

# MODEL 2900s

## 1700 Brine System

### Parts List

Item No.	Quantity	Part No.	Description
1	1	14792	Plug, End, Brine Valve
2	1	13201	Quad Ring, -020
3	1	12085	Washer, Flow, 1.2 GPM
		12086	Washer, Flow, 1.5 GPM
		12087	Washer, Flow, 2.0 GPM
		12088	Washer, Flow, 2.4 GPM
		12089	Washer, Flow, 3.0 GPM
		12090	Washer, Flow, 3.5 GPM
		12091	Washer, Flow, 4.0 GPM
		12092	Washer, Flow, 5.0 GPM
4	1	14785	Retainer, Flow Control
5	2	14811	O-ring, -210, 560CD, Brine
6	1	14798	Spacer, 1700, Brine
7	1	14795	Piston, Brine Valve
8	1	14797	Brine Valve Stem
9	1	14790	Brine Valve Body
10	1	12550	Quad Ring, -009
11	1	15310	Spring, Brine Valve
12	1	10250	Retaining Ring
13	1	15517	Guide, Stem
14	1	15415	Fitting, Insert, 1/2", Tube
15	2	15414	Nut, 2900, w/Sleeve
16	1	15413	Fitting, Elbow, Male, 1/2T x 3/8 NPT
17	1	16460	Tube, Brine, 2850, 9.123"
		<b>41447</b>	<b>Tube, Brine, 2900s, U/F</b>
18	2	16123	Nut, Brass
19	2	16124	Fitting, Sleeve, Delrin
20	1	16974	Fitting, Plstc, Female, 3/4 x 3/4 Slip - Not Shown
21	1	17777-03	Body, Injector, 1700
22	1	*14802	Throat, Injector
23	1	17777	Body, Injector, 1700
24	1	*14801	Nozzle, Injection
25	1	10229	Gasket, Injector Cap, 1600
26	1	11893	Cap, Injector, SS
		10228	Cap, Injector
27	2	14804	Screw, Hex Hd Mach, 10 - 24 x 2 3/4" 18-8 SS

**NOTE:** Item number 26 (11893) is used on injector sizes 2 through 5C. Part number 10228 is used on injector sizes 6C and 7C.

# MODEL 2900s

## 1710 Brine System

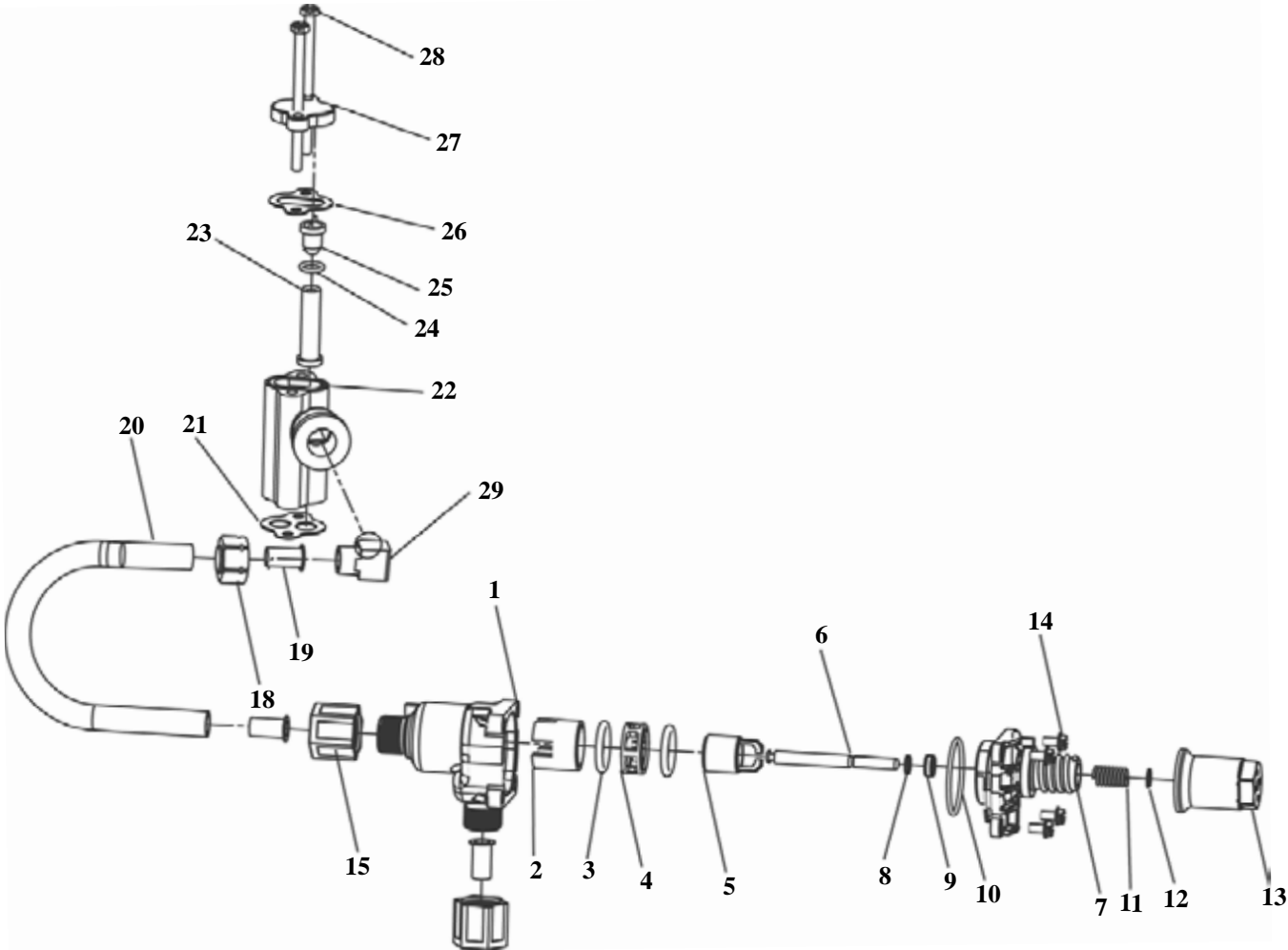

60604

# MODEL 2900s

## 1710 Brine System

### Parts List

Item No.	Quantity	Part No.	Description
1.....	1.....	41202.....	Brine Valve, 1700, Plastic, Top
2.....	1.....	14785-01.....	Retainer, Flow Control
3.....	-.....	14811.....	O-Ring, -210, 560CD, Brine
4.....	1.....	14798.....	Spacer, 1700, Brine
5.....	1.....	14795.....	Piston, Brine Valve
6.....	1.....	41203.....	Stem, Brine, 1710, Plastic, 2900
7.....	1.....	41201.....	Brine Valve, 1700, Plastic, Bottom
8.....	5.....	17908.....	Sleeve, Brine Valve Stem
9.....	1.....	12550.....	Quad Ring, -009
10.....	3.....	41547.....	O-Ring, 2mmx35mm
11.....	2.....	15310.....	Spring, Brine Valve
12.....	2.....	10250.....	Ring, Retaining
13.....	1.....	17906.....	Guide, Brine Valve Stem
14.....	2.....	14202-01.....	Screw, Hex Wsh Mach, 8-32 X 5/16 18-8 S.S.
15.....	2.....	41056.....	Nut Assembly, 1/2" Plastic
16.....	1.....	19151.....	Washer, Flow, 1.0 Gpm (not shown)
17.....	1.....	41493-00.....	Label, Blank, BLFC, 1710 (not shown)
18.....	1.....	15414.....	Nut, 2900, w/Sleeve
19.....	1.....	15415.....	Fitting, Insert, 1/2", Tube
20.....	1.....	41447.....	Tube, Brine, 2900s, U/F
21.....	1.....	19925.....	Gasket, Injector Body, 1700
22.....	1.....	17777-03.....	Body, Injector, 1700
23.....	1.....	14802-++C.....	Throat, Injector
24.....	1.....	13771.....	O-ring, -012
25.....	1.....	14801-++C.....	Nozzle, Injector
26.....	1.....	10229.....	Gasket, Injector Cap, 1600
27.....	1.....	10228.....	Cap, Injector
28.....	2.....	14804.....	Screw, Hex Head Mach, 10 - 24 x 2 3/4 18-8 S.S.
29.....	1.....	15413.....	Fitting, Elbow, Male, 1/2T X 3/8NPT

# MODEL 2900s

## Regulator Assembly 1600/1700 - Upflow

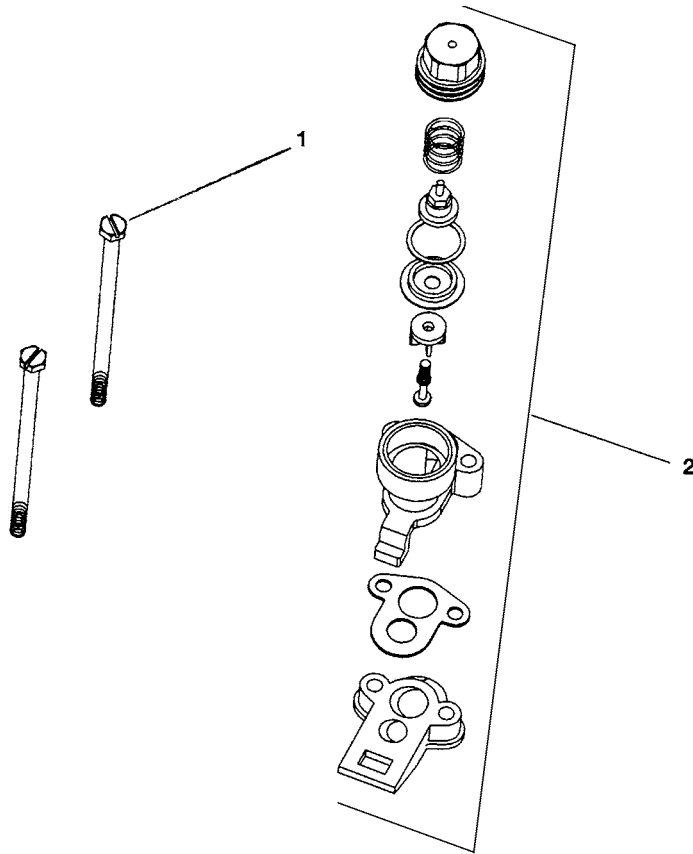

Item No.	Quantity	Part No.	Description
1	2	19718	Screw, Slot Hex Hd, #10-24
2	1	<b>40076-20</b>	<b>Cap, Injector Assy, 2750/2900s, U/F Regulated, 20PSI, Black</b>
		<b>40076-30</b>	<b>Cap, Injector Assy, 2750/2900s, U/F Regulated, 30PSI, Black</b>

## 1600/1700 System Nozzle & Throat Chart

### 1600 Brine System

#### Standard

Size	Color	Nozzle	Throat
#0	Red	10913-0	10914-0
#1	White	10913-1	10914-1
#2	Blue	10913-2	10914-2
#3	Yellow	10913-3	10914-3
#4	Green	10913-4	10914-4

#### PVC

Size	Color	Nozzle	Throat
#0	Gray	12973-0	12974-0
#1	Gray	12973-1	12974-1
#2	Gray	12973-2	12974-2
#3	Gray	12973-3	12974-3
#4	Gray	12973-4	12974-4

#### Stainless Steel

Size	Color	Nozzle	Throat
#0	Silver	10225-0	10226-0
#1	Silver	10225-1	10226-1
#2	Silver	10225-2	10226-2
#3	Silver	10225-3	10226-3
#4	Silver	10225-4	10226-4

### 1700 Brine System

#### Standard

Size	Color	Nozzle	Throat
#3	Yellow	14801-03C	14802-03C
#4	Green	14801-04C	14802-04C
#5	White	14801-05C	14802-05C
#6	Red	14801-06C	14802-06C
#7	Black	14801-07C	14802-07C

# MODEL 2900s

## 2" Brass Meter Assembly

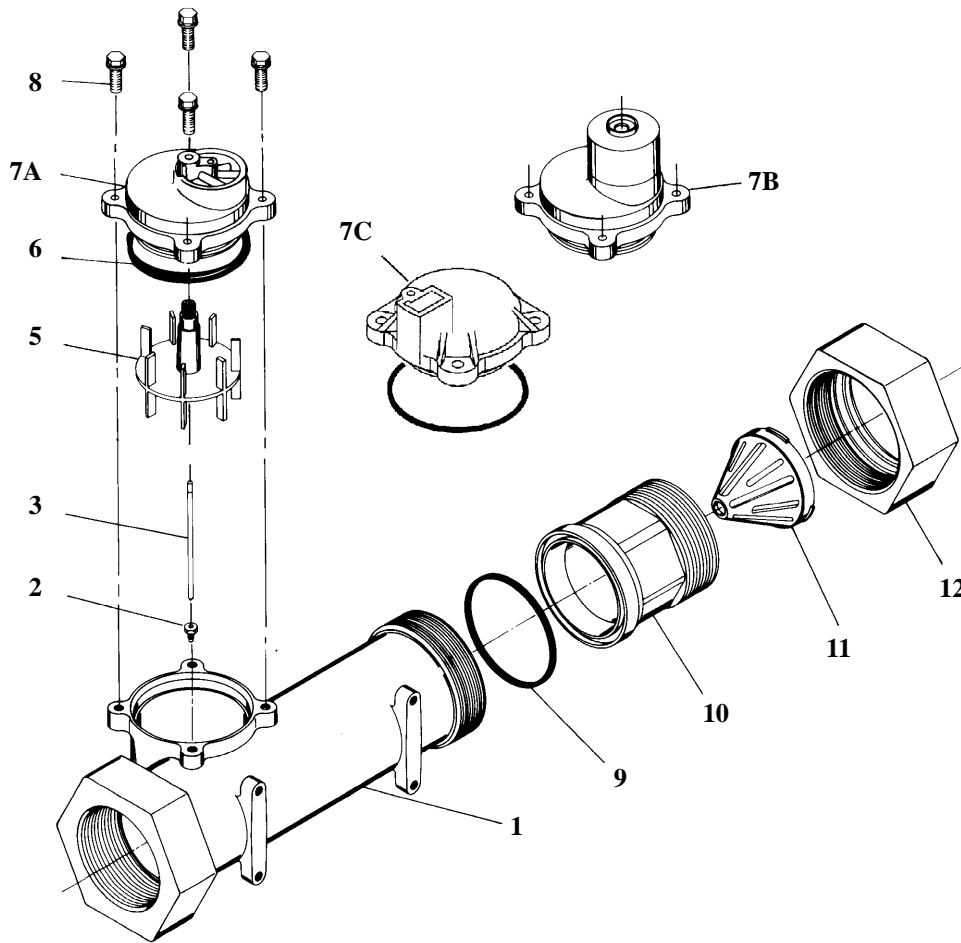

Item No.	Quantity	Part No.	Description
1	1	14456	Body, Meter, 2"
2	1	15532	Seat, Impeller Shaft, Hex
3	1	15432	Shaft
4			Not Assigned
5	1	15374	Impeller Assy, 2" Meter
6	1	13847	O-Ring, -137, Std/560CD, Meter
7A	1	15218	Meter Cap Assy
7B	1	15237	Meter Cap Assy, Ext
7C	1	14716	Meter Cap Assy, ET/NT
8	4	12112	Screw, Hex Hd Mach, 10-24 x 1/2 18-8 S.S.
9	1	14679	O-Ring, -227, Meter
10	1	14568	Fitting, Nipple, 2"
11	1	14680	Flow Straightener
12	1	14569	Nut, 2900 Meter

## 2" Plastic Meter Assembly

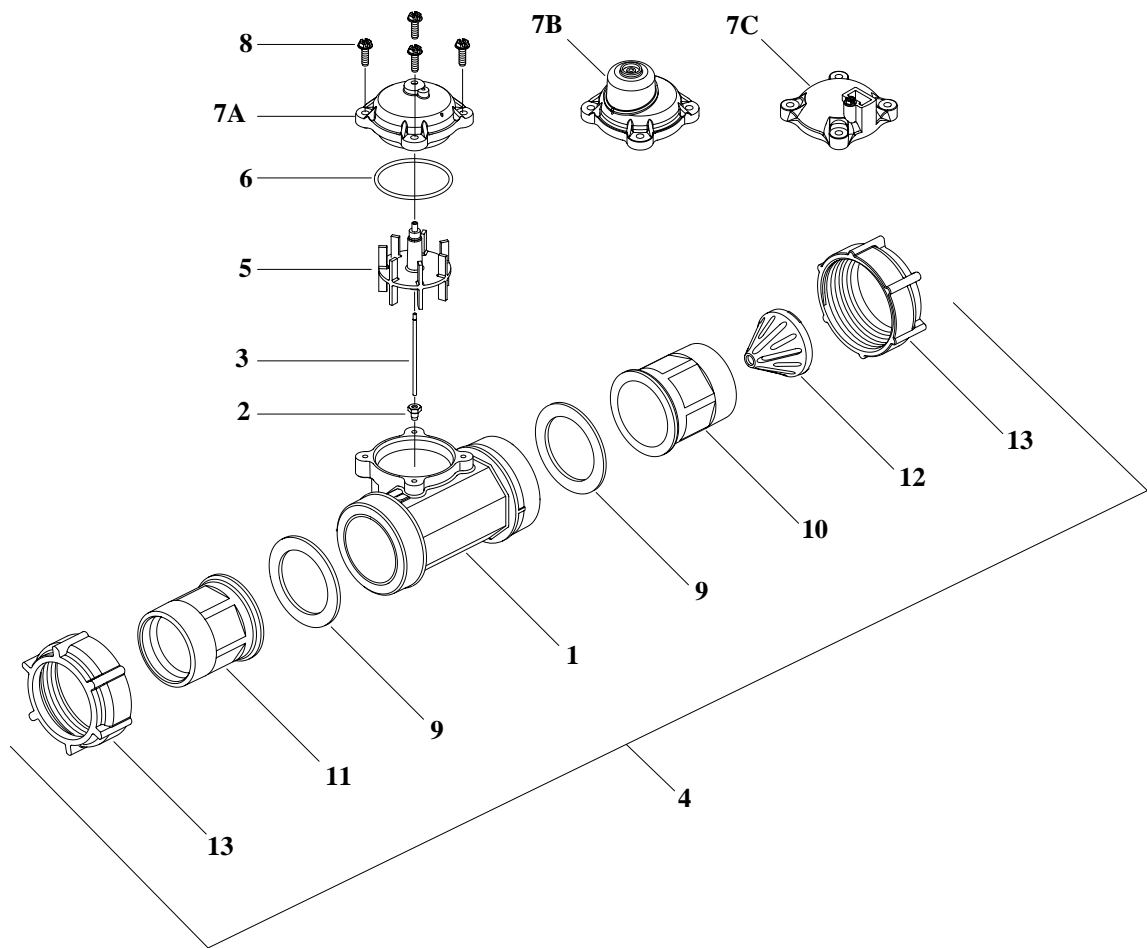

Item No.	Quantity	Part No.	Description
1	1	17689	Body, Meter, 2" Plastic w/Impeller Shaft Seat
2	1	15532	Seat, Impeller Shaft, Hex
3	1	15432	Shaft, Impeller, SS
4	1	60620	Meter Assembly, 2" Plastic, Std
		60621	Meter Assembly, 2" Plastic, Ext
		60625	Meter Assembly, 2" Plastic, Electronic
5	1	15374	Impeller Assy, 2" Meter
6	1	13847	O-Ring, -137, Std/560CD, Meter
7A	1	14038	Meter Cap Assembly
7B		15150	Meter Cap Assembly, Ext
7C		14716	Meter Cap Assy, ET/NT
8	4	12473	Screw, Hex Wsh, 10-24 x 5/8 18-8 S.S.
9	2	40666	Seal, Face, 2", Plastic Meter
10A	1	17987-001	Fitting, Nipple, 2", Plastic, NPT, Machined, Flow Straightener
10B	1	17987-101	Fitting, Nipple, 2", Plastic, BSP, Machined, Flow Straightener
11A	1	17987-000	Fitting, Nipple, 2", Plastic, NPT
11B	1	17987-100	Fitting, Nipple, 2", Plastic, BSP
12	1	14680	Flow Straightener
13	2	17988	Nut, 2" Meter

# MODEL 2900s

## 2300 Safety Brine Valve

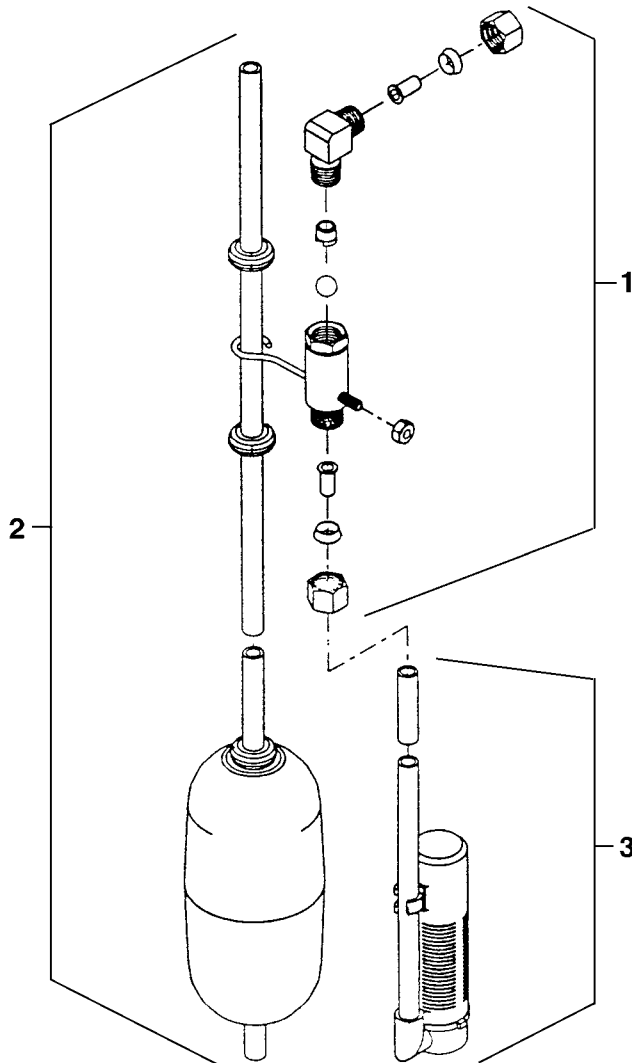

DF044-1

Item No.	Quantity	Part No.	Description
1	1	60027-FFA	Safety Brine Valve Body, 2300 Fitting Facing Arm
		60027-FFS	Safety Brine Valve Body Fitting Facing Stud
2	1	60028-30	Float Assy, 2300, 30", Blue/White
		60026-30SAN	Float Assy, 400A/2350, 30", HW
3	1	60002-34	Air Check, #500, 34" Long
		60003-34	Air Check, #500, HW, 34" Tube

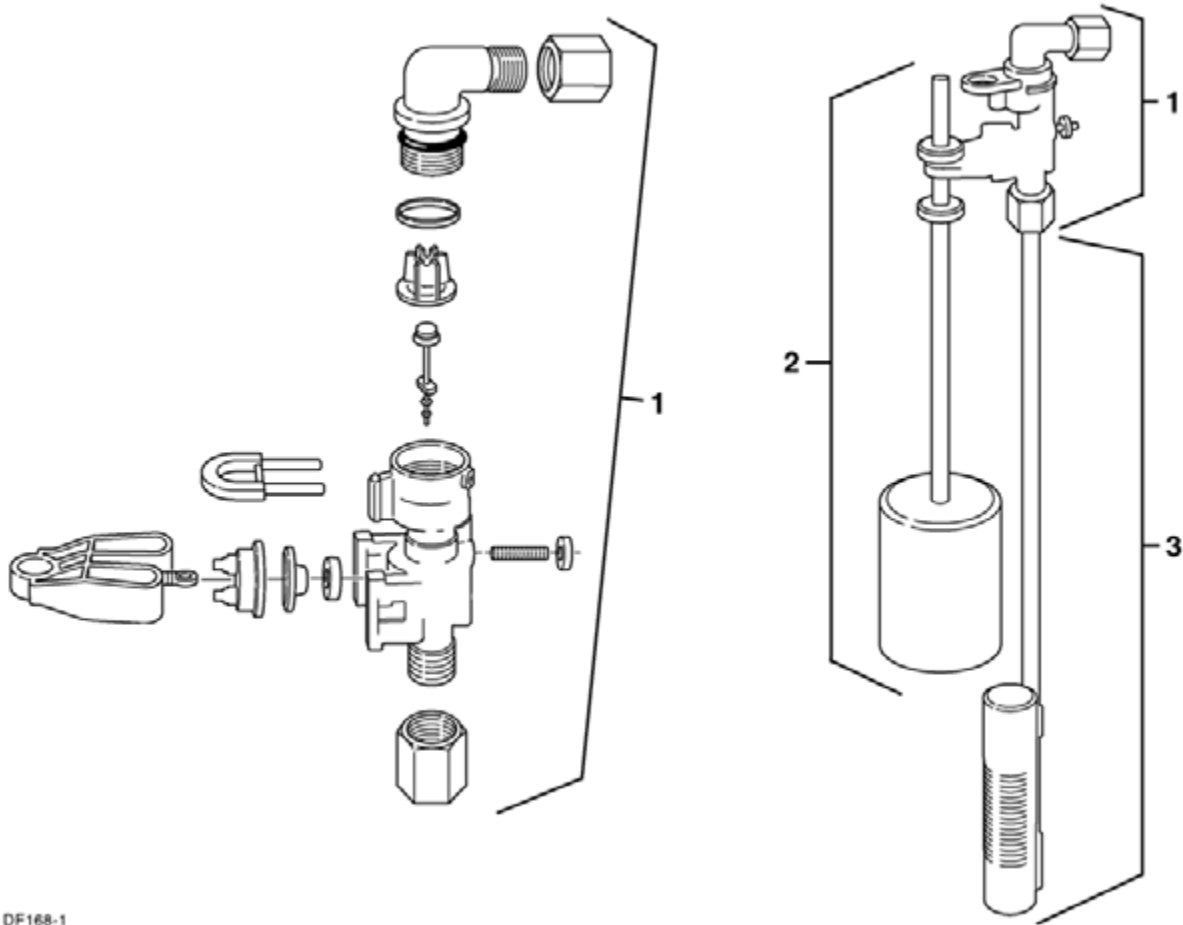

DF168-1

Item No.	Quantity	Part No.	Description
1.	1	60014	Safety Brine Valve Assy, 2310
2.	1	60068	Float Assy, 2310, w/30" Rod
		60026-30	Float Assy, 400A/2350, 30" Red/Wht
3.	1	60002-34	Air Check, #500, 34" Long

# MODEL 2900s

## 2350 Safety Brine Valve

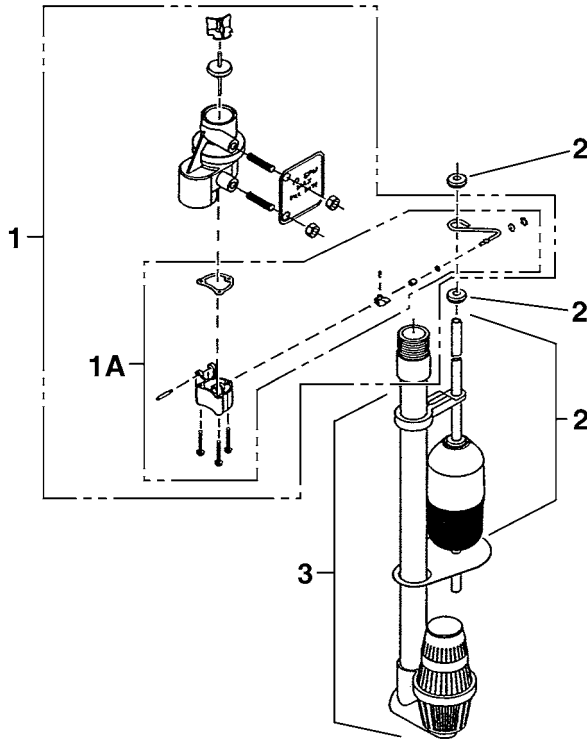

DF213-0

Item No.	Quantity	Part No.	Description
1	1	.60038	Safety Brine Valve, 2350
1A	1	.61024	Actuator Assy, 2350 Brine
2	1	.60026-30	Float Assy, 400A/2350, 30" Red/Wht
		.60026-30SAN	Float Assy, 400A/2350, 30", HW
3	1	.60009-00	Air Check, #900, Commercial Less Fittings
		.60009-01	Air Check, #900, Commercial, HW Less Fittings

**Not Shown:**

4	1	.18603	Fitting Assy, 900 Air Check, 2350
5	1	.18602	Fitting Assy, 900 Air Check

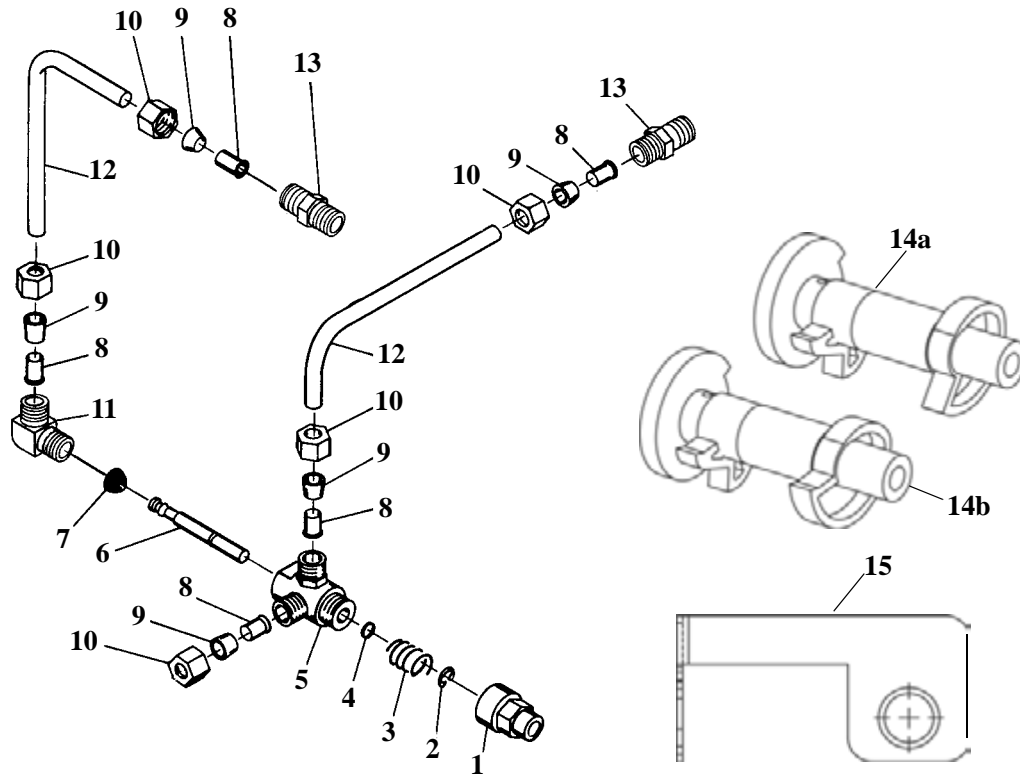

### PARTS LIST

Item No.	Quantity	Part No.	Description
1	1	11749	Guide, Brine Valve Stem
2	1	10250	Ring, Retaining
3	1	10249	Spring, Brine Valve
4	1	12550	Quad Ring, -009
5	1	10785	SVO Body Assy Brass Valves
6	1	12552	Brine Valve Stem, 1600
7	1	12626	Seat, Brine Valve
8	5	10332	Fitting, Insert, 3/8
9	5	10330	Fitting, Sleeve, 3/8 Celcon
10	5	10329	Fitting, Tube, 3/8 Nut, Brass
11	1	10328	Fitting, Elbow, 90 Deg 1/4 NPT x 3/8T
12	2	12897	Tube, Fitting, 3/8 x 9 3/4
13	2	16730	Fitting, Male, 1/4 x 1
14a	1	12472	Cam Assy, Tri-Stack, After RR
14b	1	15770	Cam Assy, Special Tri-Stack After Brine Fill
15	1	12114	Bracket, Motor Outboard, Coated

# MODEL 2900s

## Control Valve

### Side Mount Adapter

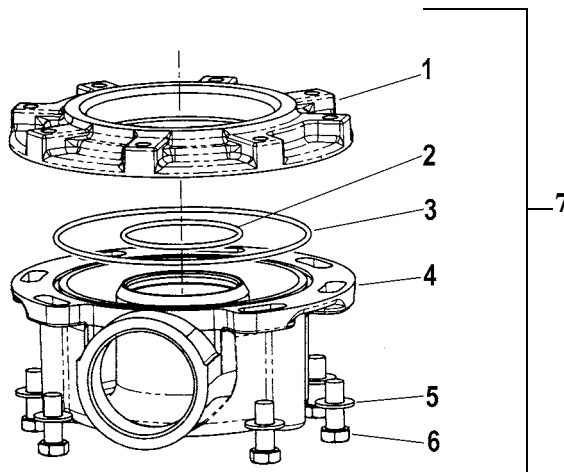

Item No.	Quantity	Part No.	Description
1	1	40316	Adapter, Sidemount
2	1	40372	O-Ring - 142
3	1	40368	O-Ring - 160, Sidemount, Flange
4	1	40310	Base, 2850/2900/3930, Rotating
5	7	40375	Washer, Flat, 3/8, Type A, N-SERS
6	7	19768	Screw, Hex Hd, 3/8 - 16 x 1, Cap 18-8
7	1	61415	Adapter Assy, Sidemount 2850/2900/2930
	.	61530	Seal & Spacer Kit, 2900s Upper
	.	61415NP	Adapter Assy, Sidemount, NP 2850/2900/2930
	.	61415-20	Adapter Assy, Sidemount, BSP/MTC 2850/2900/2930
	.	61415-20NP	Adapter Assy, Sidemount, BSP/NP 2850/2900/2930

### ADAPTERS

61525	Softwater Adapter Kit, 2900s
61415	Adapter Assy, Sidemount 2850/2900/2930
61415NP	Adapter Assy, Sidemount, NP 2850/2900/2930
61415-20	Adapter Assy, Sidemount, BSP/MTC 2850/2900/2930
61415-20NP	Adapter Assy, Sidemount, BSP/NP 2850/2900/2930

### AIR CHECKS

60002-34	Air Check, #500, 34" Long
60003-34	Air Check, #500, HW, 34" Tube
60009-01	Air Check, #900, Commercial, HW Less Fittings

### AUXILIARY MICRO SWITCH

60320-02	Switch Kit, 3200/9000 Timer Auxiliary
60320-11	Switch Assy, 2900, Lower Drive (For Adding 2nd Switch)
60320-08	Switch Assy, 2900, Lower Drive Aux (For Adding Third Switch)

### BRINE LINE FLOW (BLFC)

60020-25	BLFC, .25 GPM, 1600
60020-50	BLFC, .50 GPM, 1600
60020-100	BLFC, 1.0 GPM, 1600
60011-090	Brine Valve, 1650, Short Stem
60010-25	BLFC, 1650, .25 GPM, Plastic
60010-50	BLFC, 1650, .50 GPM, Plastic
60010-100	BLFC, 1650, 1.0 GPM, Plastic

### BRINE VALVES

60011	Brine Valve, 1650, Less BLFC
60029	Brine Valve, 1600, Short Stem Brass, Std O-rings
60029HW	Brine Valve, 1600, Short Stem Hot Water
60034-__	Model 1700 brine valve assy.( specify flow control 1.0 - 5.0 )
60064-__	Model 1710 brine valve assy.( specify flow control 1.0 - 5.0 )

### COVERS

60217-__	Environmental lower cover
60219-__	Environmental
60232-__	Designer 2 piece
60232-110	Cover, Designer, 1 Pc Black
60239-__	Designer Lower cover

### DRIAN LINE FLOW CONTROLS

60366-__	1" FNPT x 3/4" FNPT ( specify flow control .6 - 7.0)
60701-__	1" FNPT x 1" FNPT ( specify flow control 8.0 - 25.0 )
60702-__	1" FNPT x 1" MNPT ( specify flow control 8.0 - 25.0 )
60708-__	1" FNPT x 3/4" FNPT ( specify flow control 8.0 - 25.0 )
60721-__	1" FNPT x 1" FNPT ( specify flow control .6 - 7.0)

### CAM ASSEMBLY

60160-00	Drive Cam Assy, RR, White
60160-20	Drive Cam Assy, Std
60160-22	Drive Cam Assy, Link, Environmental 2900 Lower Drive
<b>60160-30</b>	<b>Drive Cam Assy, Upflow</b>
<b>60160-31</b>	<b>Drive Cam Assy, Upflow, Variable</b>

### 24 HOUR GEAR ASSEMBLY

19205	Gear Assy, 24 Hour, Silver, 5600, 12 A.M.
60519-02	Gear Assy, 3200 24 Hour 2 Times/Day, w/Silver Label
60519-03	Gear Assy, 3200, 24 Hour 3 Times/Day, w/Silver Label
60519-04	Gear Assy, 3200, 24 Hour 4 Times/Day, w/Silver Label
60519-06	Gear Assy, 3200, 24 Hour (12:00) 6 Times/Day, w/Silver Label

### INJECTOR ASSEMBLIES COMPLETE

60483-__	1700 - 1/2" brine (specify size of injector)
60480-__	1600 - 3/8" brine (specify size of injector)
60481-__	1600 Brass - 3/8" brine ( specify size of injector)

### METERS

60393	Meter Assy, 2900, 2" Std
60394	Meter Assy, 2900, 2" Std
60616	Meter Assy, Elec 2"
60620	Meter Assy, 2" Plastic, Std
60621	Meter Assy, 2" Plastic, Std
60625	Meter Assy, 2" Plastic Electronic
61439	Meter Sleeve w/O-ring, Machd

### PISTON ASSEMBLIES

<b>61545</b>	<b>Piston Assy, 2900s, Upflow Upper</b>
<b>61545-01</b>	<b>Piston Assy, 2900s, Upflow Upper, HW</b>
61540	Piston Assy, 2900s, Downflow Upper
61540-01	Piston Assy, 2900s Downflow Upper, HW
61550	Piston Assy, 2900s, HWBP Lower
61550-01	Piston Assy, 2900s, HWBP Lower, HW, Sft Wtr Adp
61550-02	Piston Assy, 2900s, HWBP Lower, Sft Wtr Adp
61550-03	Piston Assy, 2900s, HWBP Lower, HW
61555	Piston Assy, 2900s, NHWBP Lower
61555-01	Piston Assy, 2900s, NHWBP Lower, HW, Sft Wtr Adp
61555-02	Piston Assy, 2900s, NHWBP Lower, Sft Wtr Adp
61555-03	Piston Assy, 2900s, NHWBP Lower, HW

### PROGRAM WHEEL ASSEMBLIES

60405-20	Program Wheel, w/3/4" Ext Label 1 1/2" Std Set @ 100
60405-50	Program Wheel, w/2" Std Label Set @ 21
60405-60	Program Wheel, w/2" Ext Label
60405-70	Program Wheel, w/1 1/2" Ext Label

### SAFETY BRINE VALVES

60014	Safety Brine Valve Assy, 2310
60038	Safety Brine Valve , 2350
60026-30	Float Assy, 400A/2350, 30" Red/Wht
60026-30SAN	Float Assy, 400A/2350, 30" HW
60027-FFA	Safety Brine Valve Body, 2300 Fitting Facing Arm
60027-FFS	Safety Brine Valve Body Fitting Facing Stud
60028-30	Float Assy, 2300, 30", Blue/White
60068-30	Float Assy, 2310, w/30" Rod

### SALES AND SERVICE AIDS

40738	Literature, 2900 Spec Sheet
41689	Literature, 2900s S/Manual
40717	Literature, Catalog Assy, PWT Residential/Commercial

### SEAL & SPACER KITS

61530	Seal & Spacer Kit, 2900s Upper
61530-01	Seal & Spacet Kit, 2900s, HW Upper
60128	Seal & Spacer Kit, 2900/2930 Lower
60128-01	Seal & Spacer Kit, 2900/2930, HW Lower

### SERVICE EQUIPMENT

11098	Stuffer Tool Assy, Complete
12682	Puller Tool Assy, 2900/3150
12683	Stuffer Tool Assy, 2900/3150
13061	Puller Assy, Port Ring
16174	Silicone, 2 oz. Tube
60460	Meter Checker Kit, Std
60461	Meter Checker Kit, Ext
16586-8	Silicone, Dow #7 8 Lb

### SERVICE VALVE OPERATOR ASSEMBLY ( SVO )

60150	SVO Assy, 1600 O/S
60150-01	SVO Assy, 1600 N/S

### SKIPPER WHEEL ASEMBLIES

14860	Skipper Wheel Assy, 7 Day
14381	Skipper Wheel Assy, 12 Day

# MODEL 2900s

## Service Instructions

PROBLEM	CAUSE	CORRECTION
1. Softener Fails To Regenerate.	A. Electrical Service To Unit Has Been Interrupted. B. Timer Is Defective. C. Power Failure.	A. Assure Permanent Electrical Service (Check Fuse, Plug, Pull Chain or Switch). B. Replace Timer. C. Reset Time of Day.
2. Hard Water.	A. By-Pass Valve is Open. B. No Salt in Brine Tank C. Injector Screen Plugged. D. Insufficient Water Flowing Into Brine Tank E. Hot Water Tank Hardness. F. Leak At Distributor Tube. G. Internal Valve Leak H. Service Adapter Did Not Return To Service.	A. Close By-Pass Valve. B. Add Salt To Brine Tank and Maintain Salt Level Above Water Level. C. Clean Injector Screen. D. Check Brine Tank Fill Time And Clean Brine Line Flow Control If Plugged. E. Repeated Flushings Of The Hot Water Tank is Required. F. Make Sure Distributor Tube Is Not Cracked. Check O-Ring And Tube Pilot. G. Replace Seals and Spacers And/Or Piston. H. Check Drive Motor And Switch.
3. Unit Used Too Much Salt	A. Improper Salt Setting. B. Excessive Water in Brine Tank	A. Check Salt Usage and Salt Setting. B. See Problem No. 7.
4. Loss Of Water Pressure.	A. Iron Buildup In Line To Water Conditioner. B. Iron Buildup in Water Conditioner. C. Inlet of Control Plugged Due to Foreign Material Broken Loose From Pipes By Recent Work Done On Plumbing System.	A. Clean Line To Water Conditioner. B. Clean Control and Add Mineral Cleaner to Mineral Bed. Increased Frequency of Regeneration. C. Remove Piston and Clean Control.
5. Loss of Mineral Through Drain Line.	A. Air In Water System. B. Improperly Sized Drain Line Flow Control.	A. Assure That Well System Has Proper Air Eliminator Control. Check For Dry Well Condition. B. Check For Proper Drain Rate.
6. Iron In Conditioned Water.	A. Fouled Mineral Bed.	A. Check Backwash, Brine Draw And Brine Tank Fill. Increase Frequency of Regeneration. Increase Backwash Time.

## Service Instructions (Cont'd.)

PROBLEM	CAUSE	CORRECTION
7. Excessive Water In Brine Tank.	<ul style="list-style-type: none"> <li>A. Plugged Drain Line Flow Control.</li> <li>B. Plugged Injector System.</li> <li>C. Timer Not Cycling.</li> <li>D. Foreign Material In Brine Valve.</li> <li>E. Foreign Material In Brine Line Flow Control.</li> </ul>	<ul style="list-style-type: none"> <li>A. Clean Flow Control.</li> <li>B. Clean Injector and Screen.</li> <li>C. Replace Timer.</li> <li>D. Replace Brine Valve Seat And Clean Valve.</li> <li>E. Clean Brine Line Flow Control.</li> </ul>
8. Softener Fails To Draw Brine.	<ul style="list-style-type: none"> <li>A. Drain Line Flow Control Is Plugged.</li> <li>B. Injector Is Plugged.</li> <li>C. Injector Screen Plugged.</li> <li>D. Line Pressure Is Too Low.</li> <li>E. Internal Control Leak</li> <li>F. Service Adapter Did Not Cycle.</li> </ul>	<ul style="list-style-type: none"> <li>A. Clean Drain Line Flow Control.</li> <li>B. Clean Injector.</li> <li>C. Clean Screen.</li> <li>D. Increase Line Pressure To 20 P.S.I.</li> <li>E. Change Seals, Spacers and Piston Assembly.</li> <li>F. Check Drive Motor And Switches.</li> </ul>
9. Control Cycles Continuously.	<ul style="list-style-type: none"> <li>A. Misadjusted, Broken or Shorted Switch.</li> </ul>	<ul style="list-style-type: none"> <li>A. Determine If Switch or Timer Is Faulty and Replace It or Replace Complete Power Head.</li> </ul>
10. Drain Flows Continuously.	<ul style="list-style-type: none"> <li>A. Valve Is Not Programming Correctly.</li> <li>B. Foreign Material In Control.</li> <li>C. Internal Control Leak</li> </ul>	<ul style="list-style-type: none"> <li>A. Check Timer Program and Positioning of Control. Replace Power Head Assembly If Not Positioning Properly.</li> <li>B. Remove Power Head Assembly And Inspect Bore. Remove Foreign Material and Check Control In Various Regeneration Positions.</li> <li>C. Replace Seals and Piston Assembly.</li> </ul>

### General Service Hints For Meter Control

Problem: Softener Delivers Hard Water.

Cause could be that . . . . Reserve Capacity Has Been Exceeded.

Correction: Check salt dosage requirements and reset program wheel to provide additional reserve.

Cause could be that . . . . Program Wheel Is Not Rotating With Meter Output

Correction: Pull cable out of meter cover and rotate manually. Program wheel must move without binding and clutch must give positive "clicks" when program wheel strikes regeneration stop. If it does not, replace timer.

Cause could be that . . . . Meter Is Not Measuring Flow.

Correction: Check meter with meter checker.

# MODEL 2900s - Downflow

## 1 SERVICE POSITION

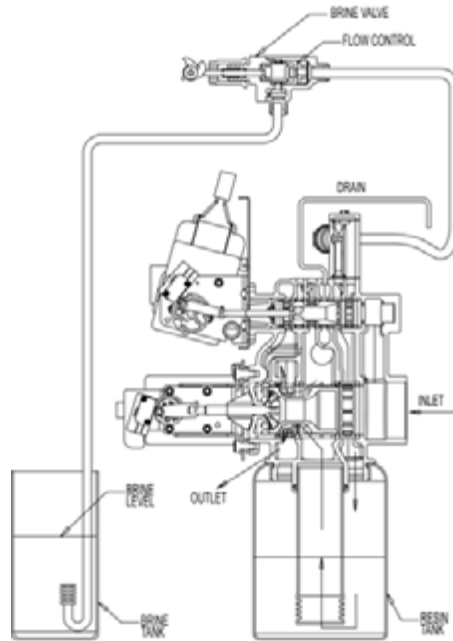

Hard water enters unit at valve inlet and flows down thru the mineral in the mineral tank. Conditioned water enters center tube thru the bottom distributor — then flows up thru the center tube — around the piston and out the side outlet of the valve.

## 2 BACKWASH POSITION

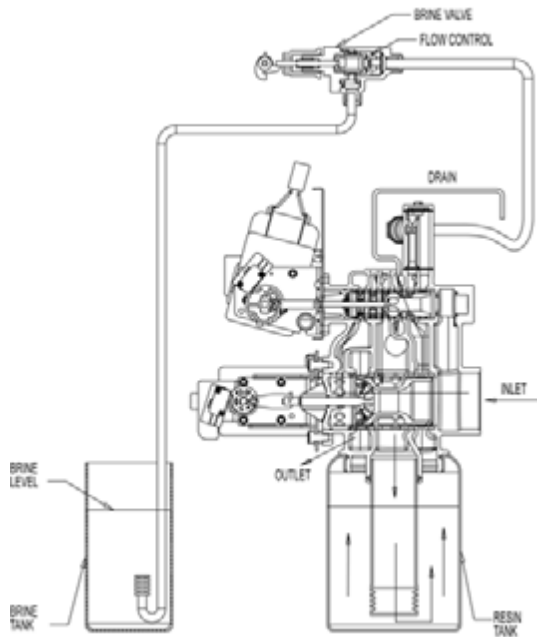

Hard water enters unit at valve inlet — flows to the front passage and up through the front passage to regenerating valve — down the center tube — thru the bottom distributor and up thru the mineral — around the piston and out the drain line. If optional no hard water by pass piston is used water flow to outlet is prevented by an extended section of the service piston which closes the outlet port from by pass water until the end of rapid rinse.

## 3 BRINE POSITION

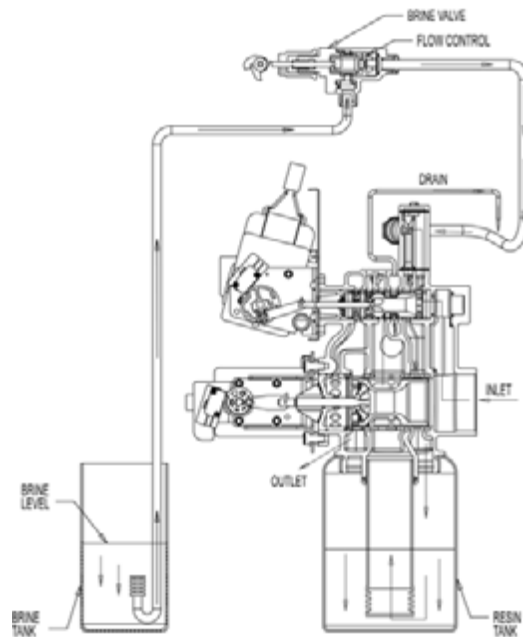

Hard water enters unit at valve inlet — flows up into injector housing and down thru nozzle and orifice to draw brine from the brine tank — brine flows down thru mineral and enters the center tube thru bottom distributor — flows up thru center tube — around the piston and out thru the drain line.

## 4 SLOW RINSE POSITION

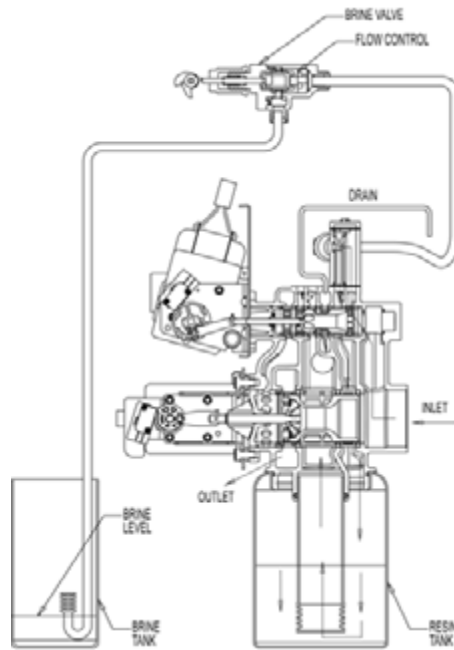

Hard water enters unit at valve inlet — flows up into injector housing and down thru nozzle and orifice — around the piston — down thru mineral — enters center tube thru bottom distributor — flows up thru center tube — around piston and out thru the drain line.

## 5 RAPID RINSE

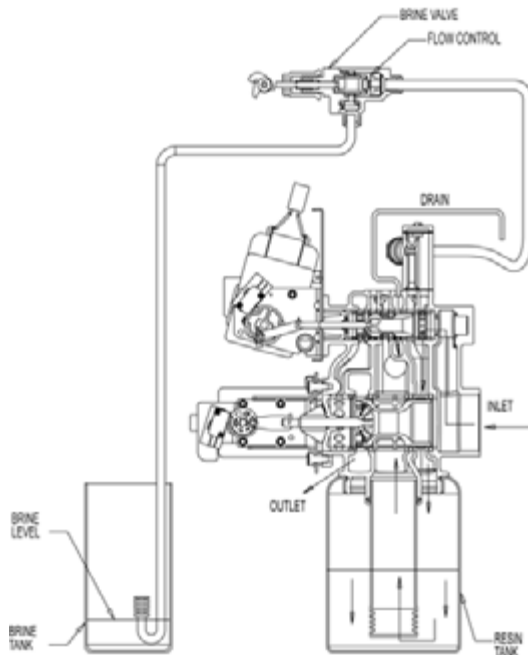

Hard water flows thru the regenerating valve directly down thru the mineral into the bottom distributor and up thru the center tube — around the piston and out the drain line.

## 6 BRINE TANK FILL POSITION

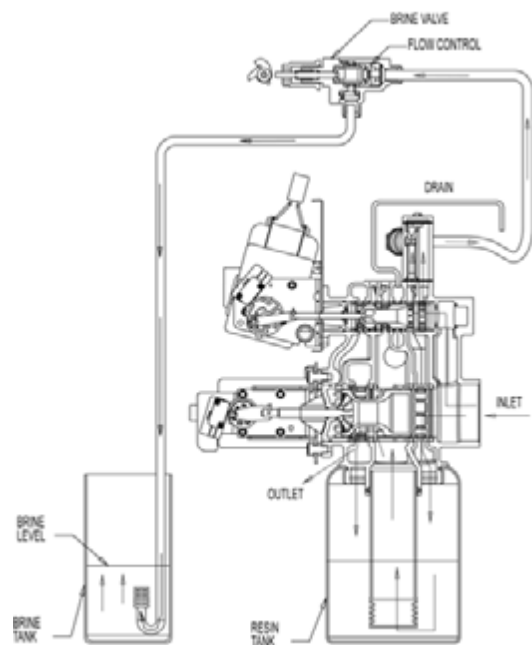

Hard water flows thru the service valve and down thru the mineral. Conditioned water enters the bottom distributor — flows up the center tube around the piston to the outlet. Hard water flows to the regenerating valve thru the injector housing and brine valve to fill the brine tank.

# MODEL 2900s - Upflow

## 1 SERVICE POSITION

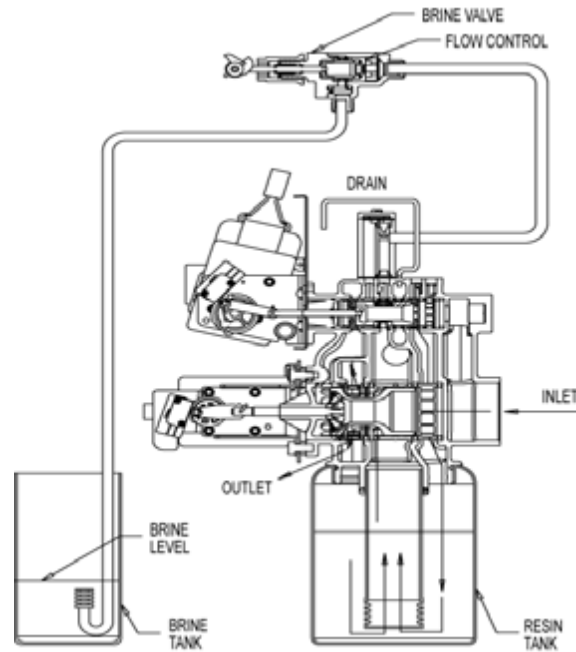

Hard water enters unit at valve inlet and flows down thru the mineral in the mineral tank. Conditioned water enters center tube thru the bottom distributor — then flows up thru the center tube — around the piston and out the top outlet of the valve.

## 2 BRINE POSITION

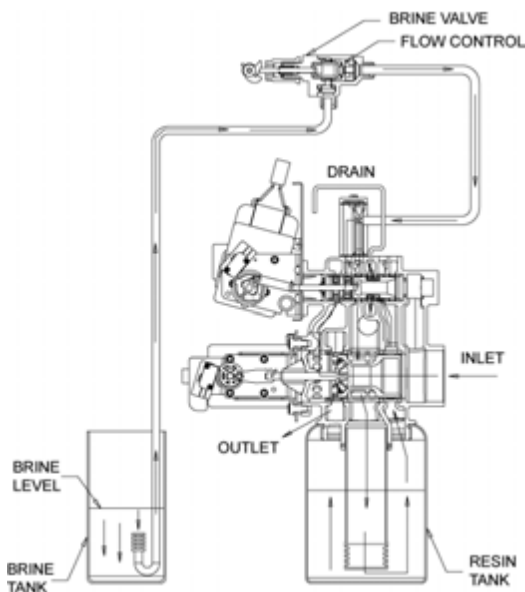

Hard water enters unit at valve inlet — flows up into injector housing and down thru nozzle and orifice to draw brine from the brine tank — brine flows down the center tube thru bottom of tank, up thru mineral to top of tank, around piston and out thru the drain line.

## 3 SLOW RINSE POSITION

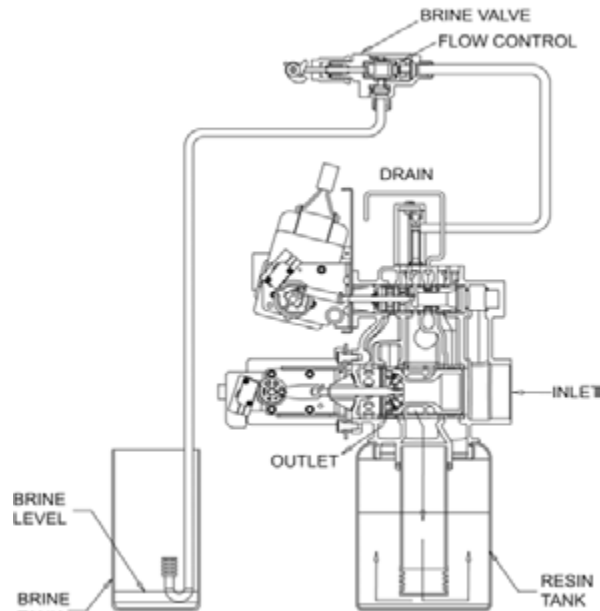

Hard water enters unit at valve inlet — flows up into injector housing and down thru nozzle and orifice — around the piston — down thru center tube thru bottom distributor — flows up thru mineral — around piston and out thru the drain line.

## 4 BACK WASH POSITION

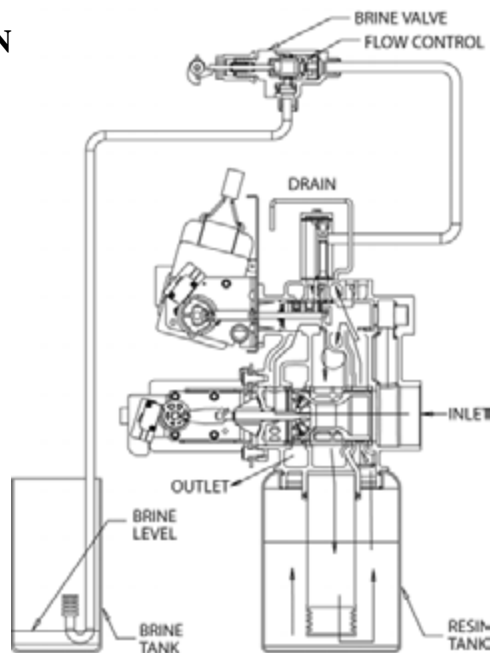

Hard water enters unit at valve inlet — flows thru service adapter for by pass, and up thru coupling to regenerating valve inlet. It then flows thru the regenerating valve piston — down the center tube — thru the bottom distributor and up thru the mineral — around the piston and out the drain line. If optional no hard water by pass piston is used water flow to outlet is prevented by an extended section of the service piston which closes the outlet port from by pass water until the end of rapid rinse.

## 5 RAPID RINSE

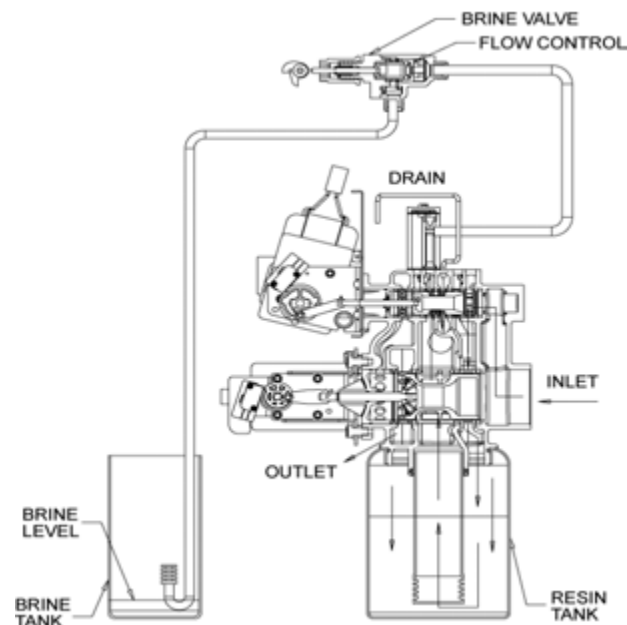

Hard water flows thru the regenerating valve directly down thru the mineral into the bottom distributor and up thru the center tube — around the piston and out the drain line.

## 6 BRINE TANK FILL POSITION

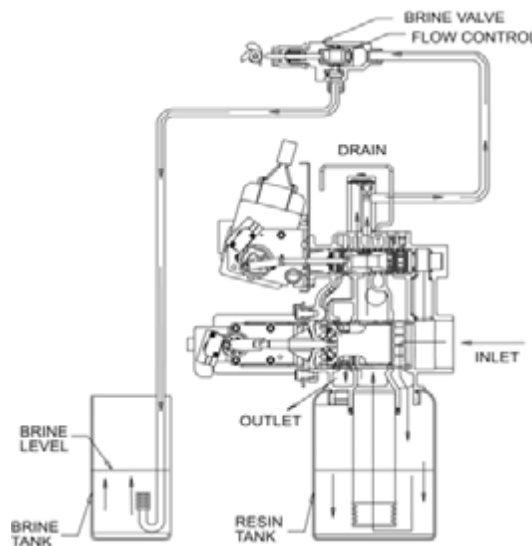

Hard water flows thru the service valve and down thru the mineral. Conditioned water enters the bottom distributor flows up the center tube around the piston to the outlet. Hard water flows to the regenerating valve thru the injector housing and brine valve to fill the brine tank.

# MODEL 2900s - Upflow

## Tank with Pressure Regulator

2900 on Tank w/Resin and 100% Brine  
with Pressure Regulator

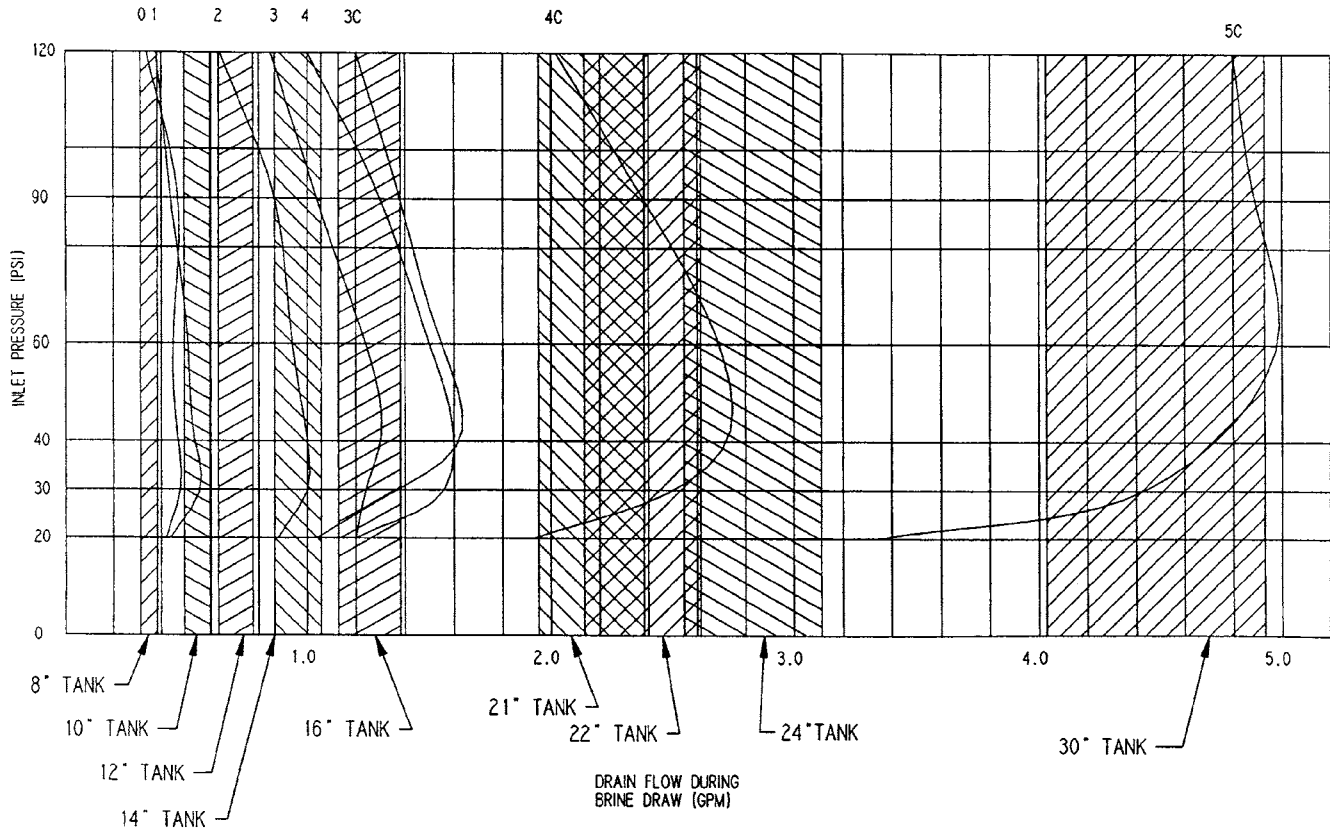

## Flow Data & Injector Draw Rates - Downflow

2900 Down Flow Valve  
Backwash, Service and Rapid Rinse  
Pressure Differential

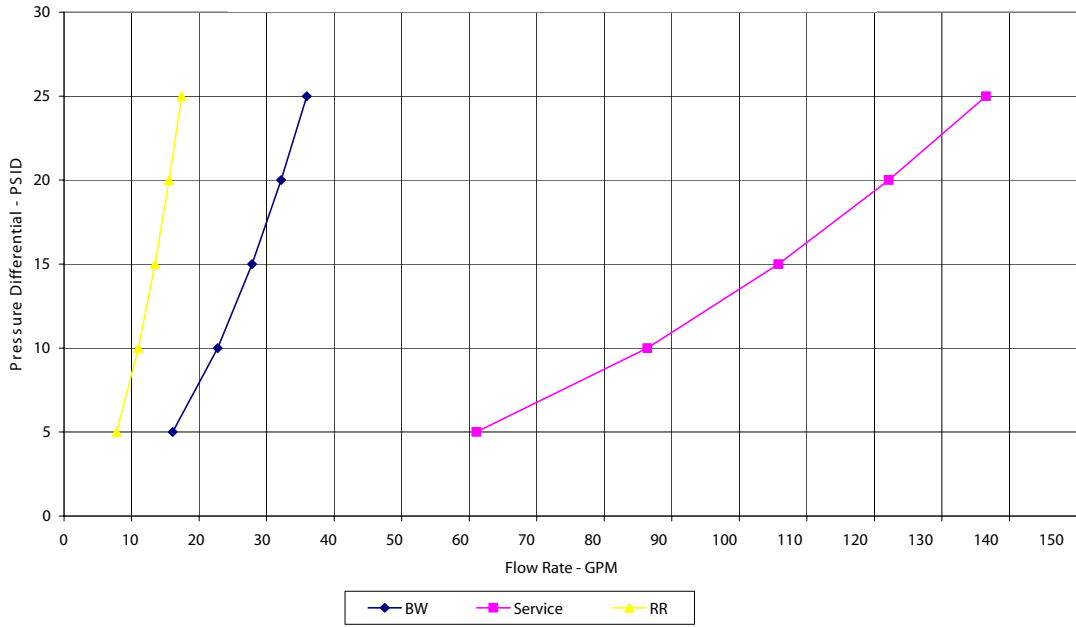

2900 Treated Water Down Flow Valve  
Backwash, Service and Rapid Rinse  
Pressure Differential

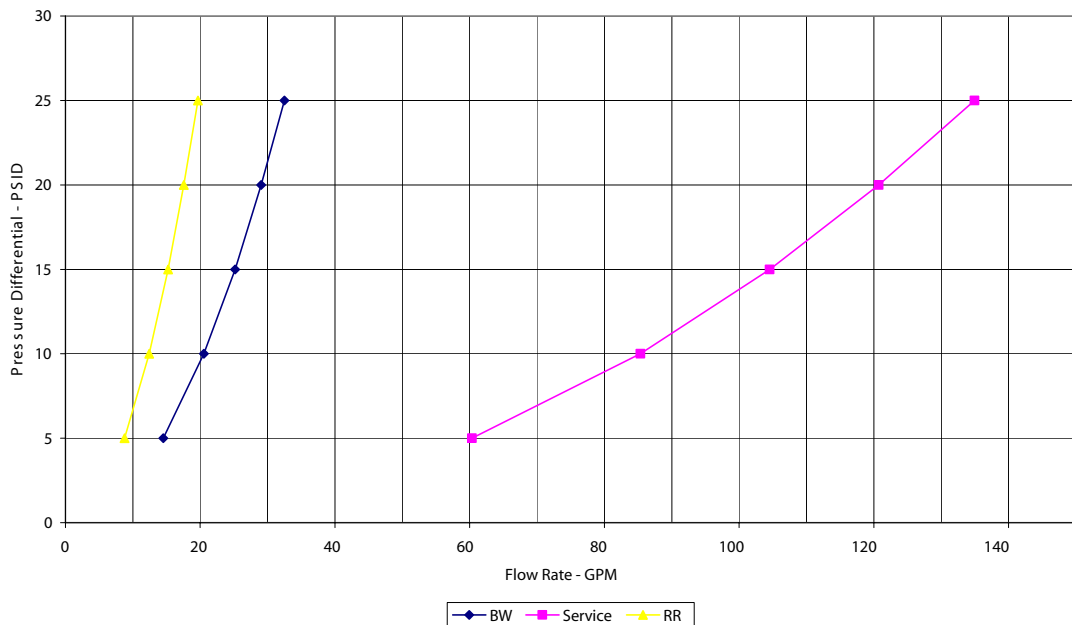

# MODEL 2900s

## Flow Data & Injector Draw Rates - Downflow

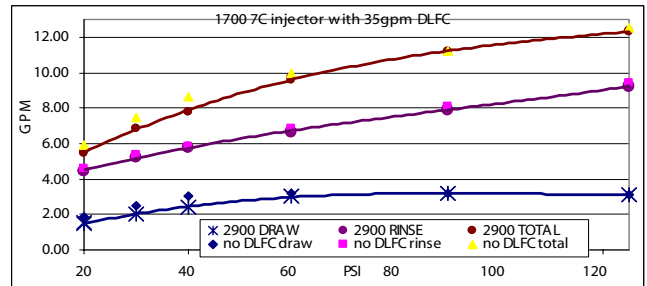
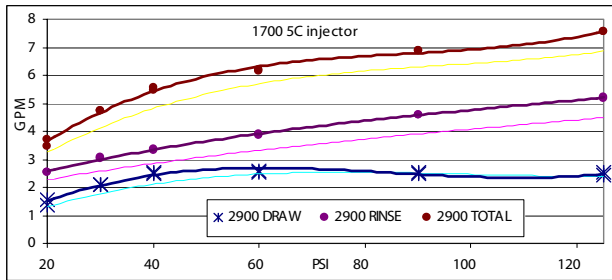
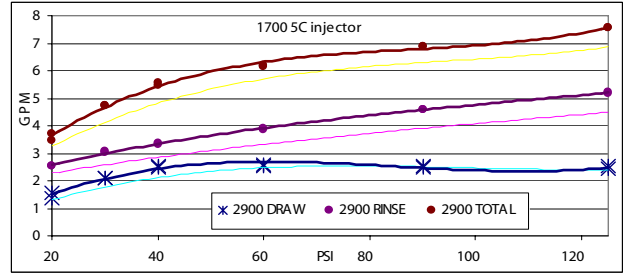
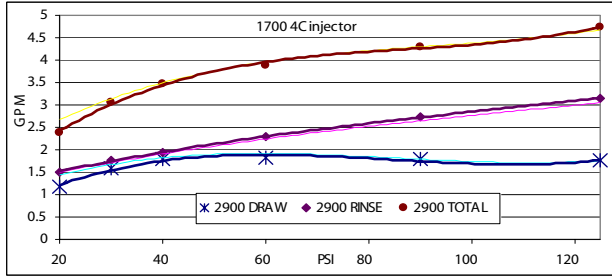
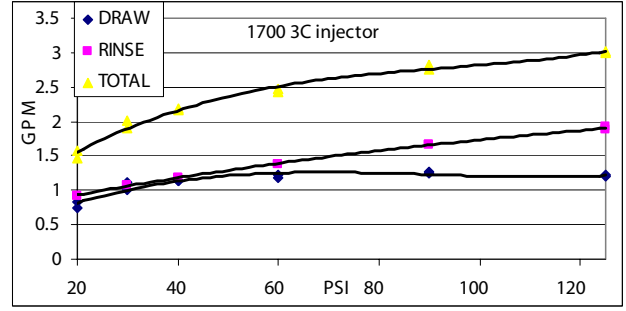
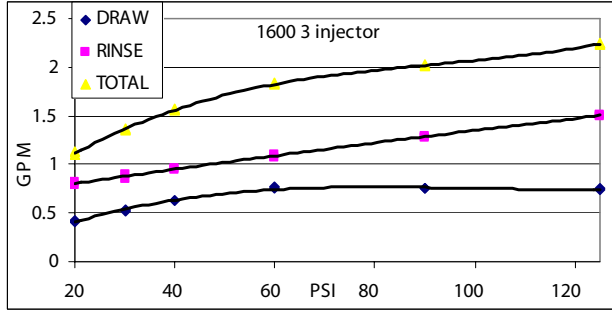

TR203941  
41606

## *Environmental Backplate Line Drawing/Distributor Cut Height*

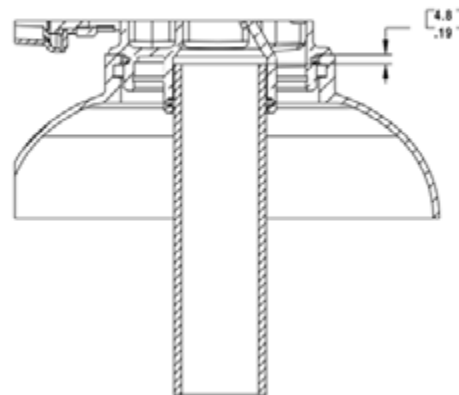
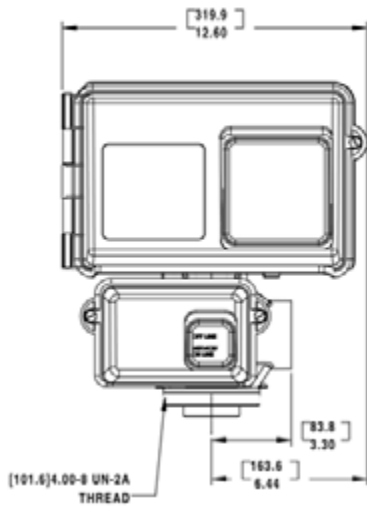
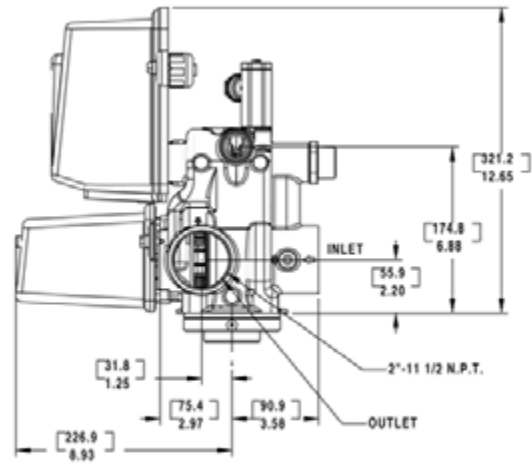
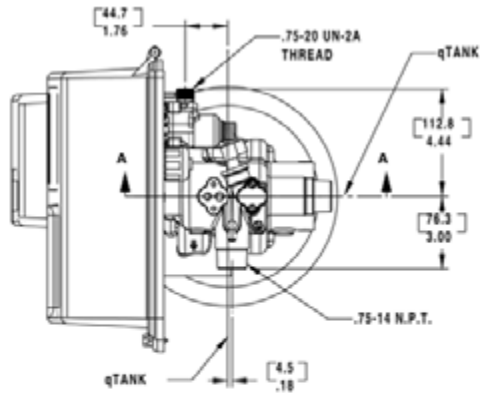

# MODEL 2900s

## Designer Backplate Line Drawing

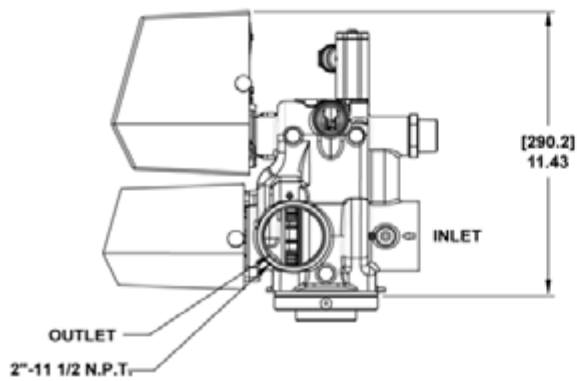
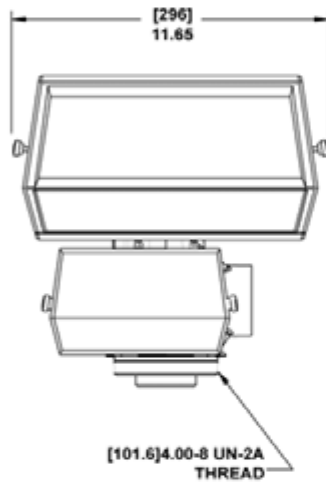
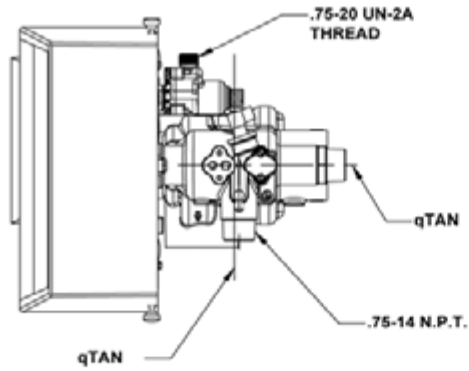

## System #4 - Typical Single Tank Installation With Optional Meter

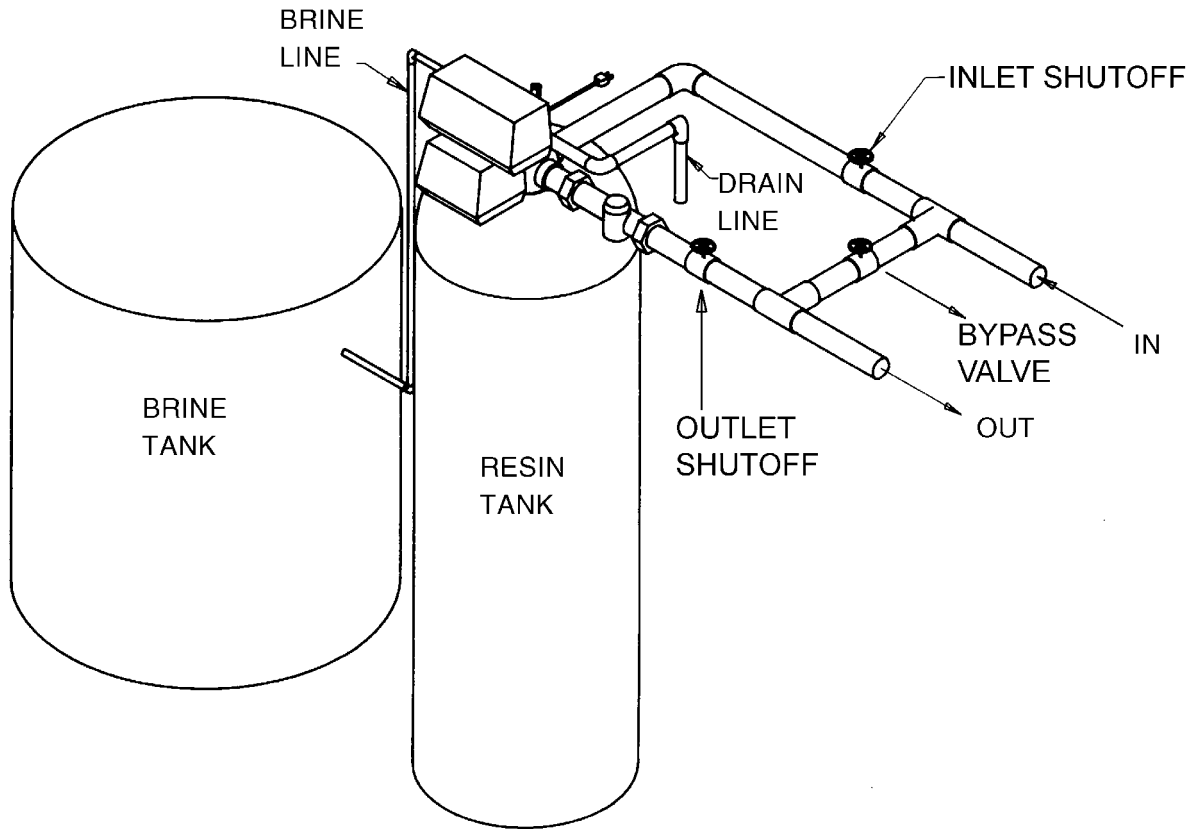

# MODEL 2900s

## System #5 - Interlock - Typical Twin Tank Installation With Optional Meter Interlock And No Hard Water Bypass

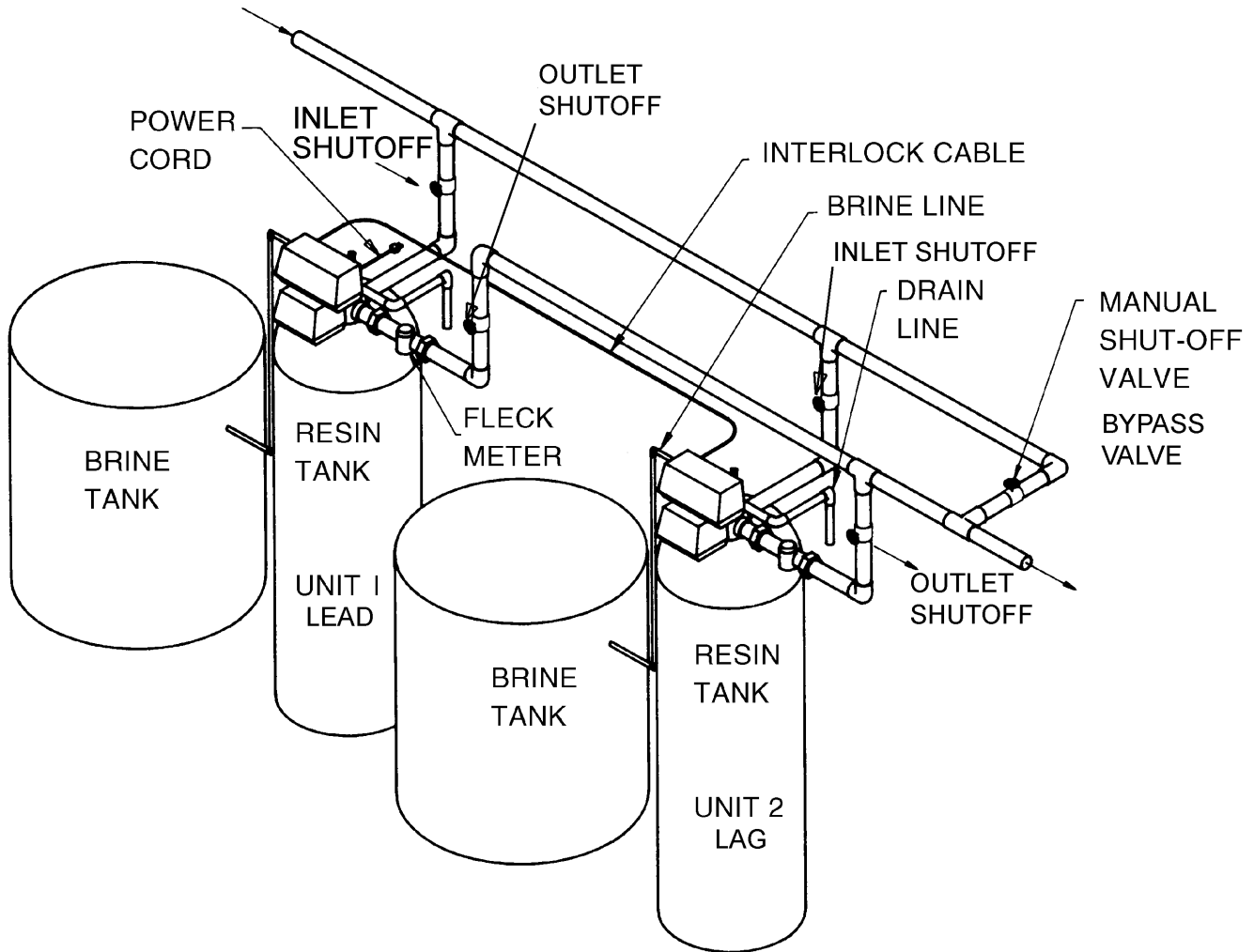

## System #6 – Twin Series Regeneration

## System #7 – Twin Alternator Installation

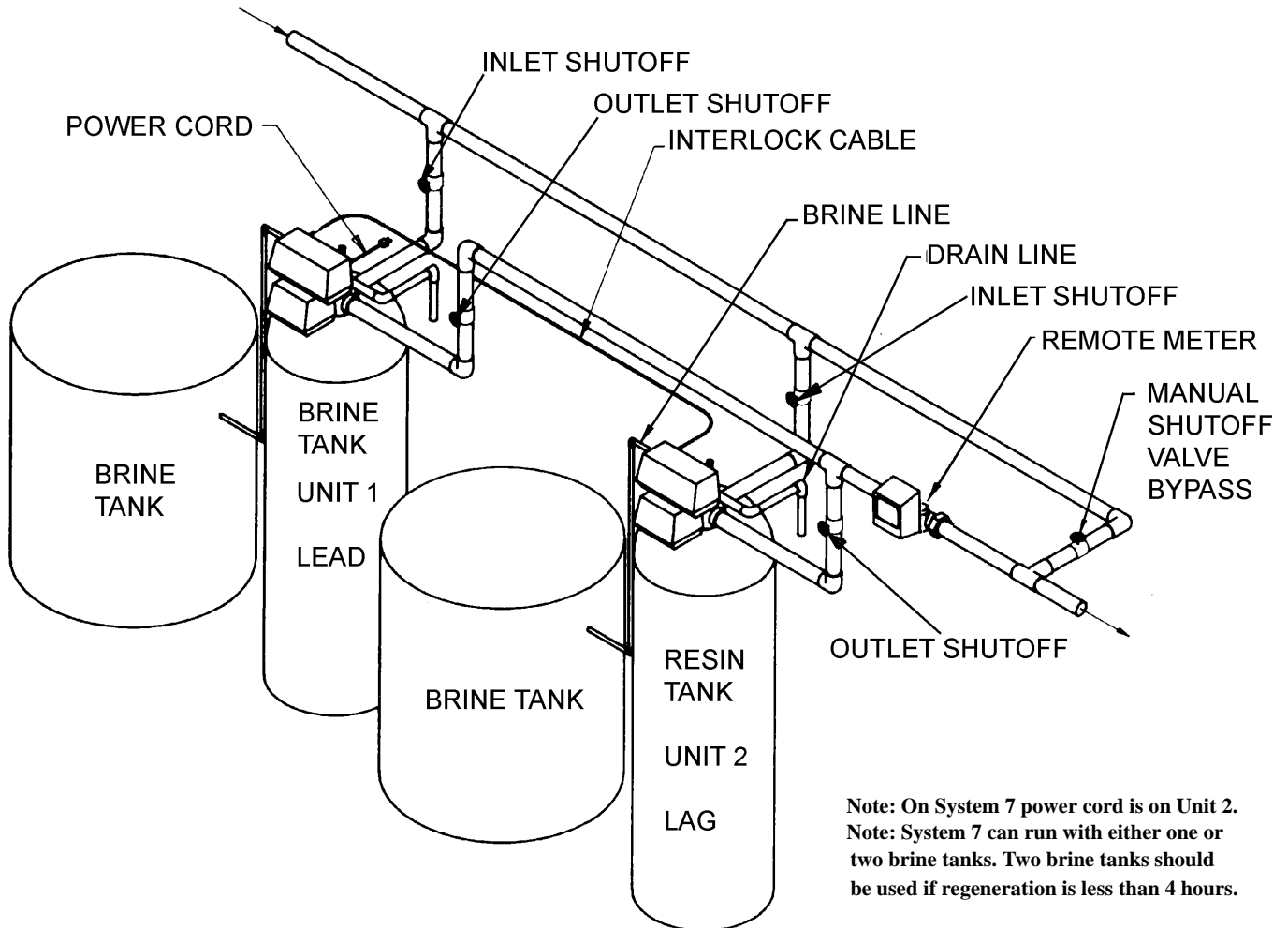

# MODEL 2900s

## System #4-Single Valve Regeneration

### Immediate and Delayed Valve Wiring

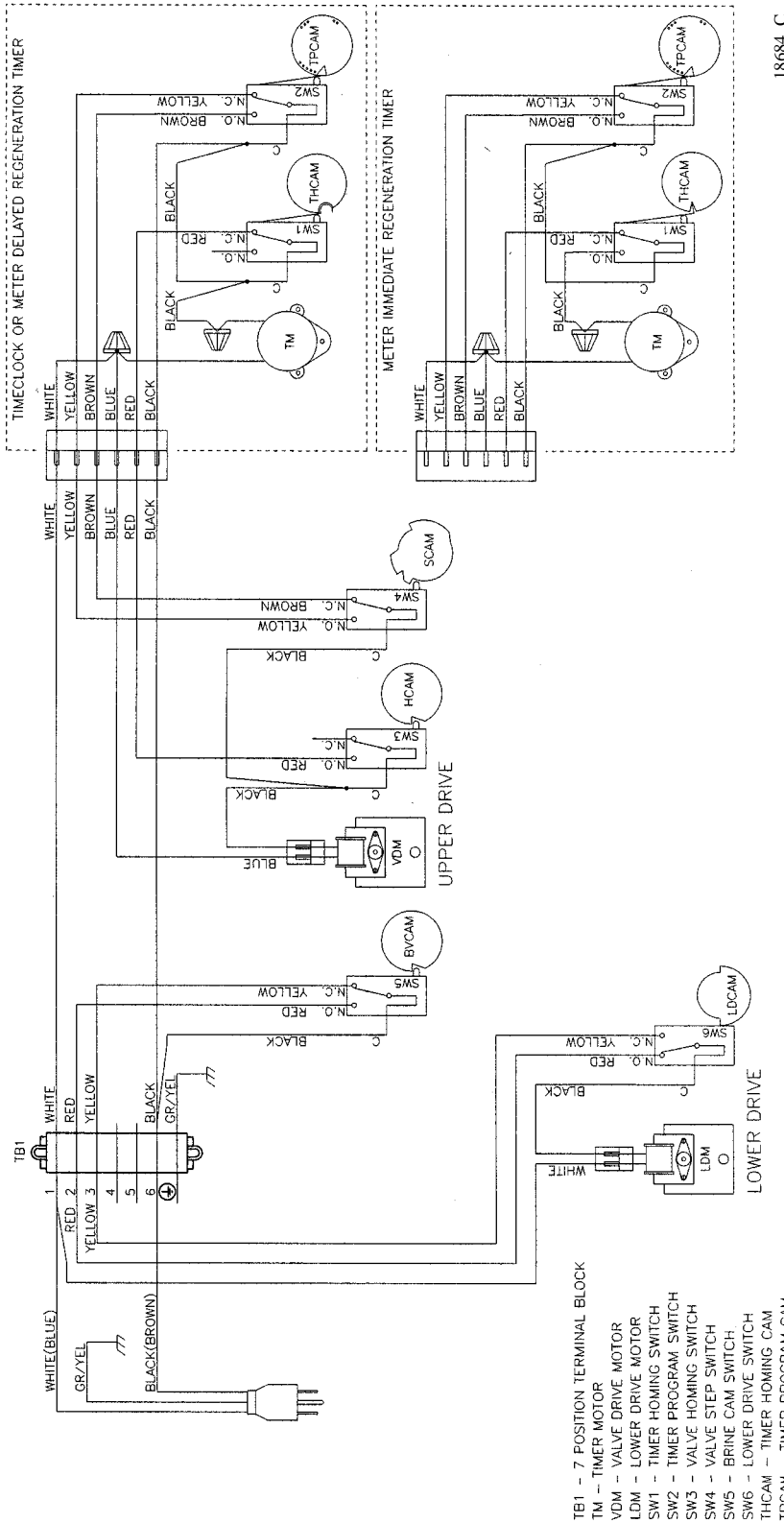

18684\_C



# MODEL 2900s

## System #5-Interlocked Regeneration

### Valve Wiring

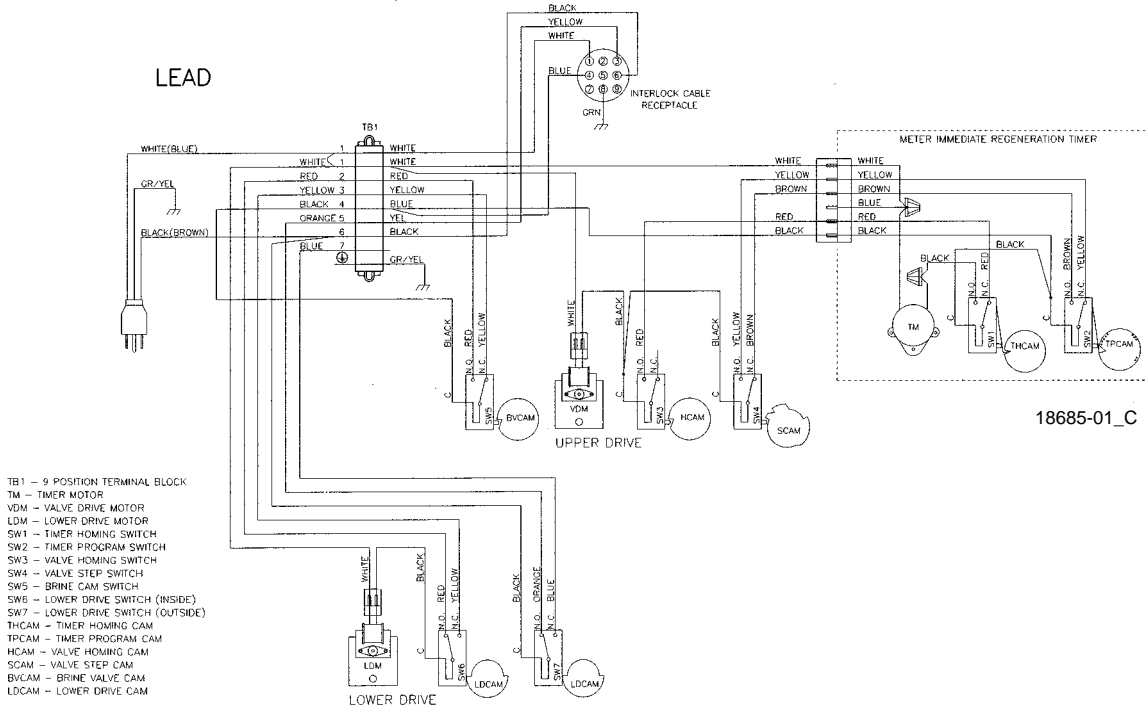

- TB1 - 9 POSITION TERMINAL BLOCK  
 TM - TIMER MOTOR  
 VDM - VALVE DRIVE MOTOR  
 LDM - LOWER DRIVE MOTOR  
 SW1 - TIMER HOMING SWITCH  
 SW2 - TIMER PROGRAM SWITCH  
 SW3 - VALVE HOMING SWITCH  
 SW4 - VALVE STEP SWITCH  
 SW5 - BRINE CAM SWITCH  
 SW6 - LOWER DRIVE SWITCH (INSIDE)  
 SW7 - LOWER DRIVE SWITCH (OUTSIDE)  
 THCAM - TIMER HOMING CAM  
 TPCAM - TIMER PROGRAM CAM  
 HCAM - VALVE HOMING CAM  
 SCAM - VALVE STEP CAM  
 BVCAM - BRINE VALVE CAM  
 LDCAM - LOWER DRIVE CAM

- NOTE:  
 1. TWO TANK INTERLOCKED, INDIVIDUAL METER, IMMEDIATE REGENERATION.  
 2. BOTH TANKS NORMALLY IN SERVICE. ONLY ONE TANK IN REGENERATION, THE OTHER REMAINS IN SERVICE.  
 3. VALVE SHOWN IN SERVICE.

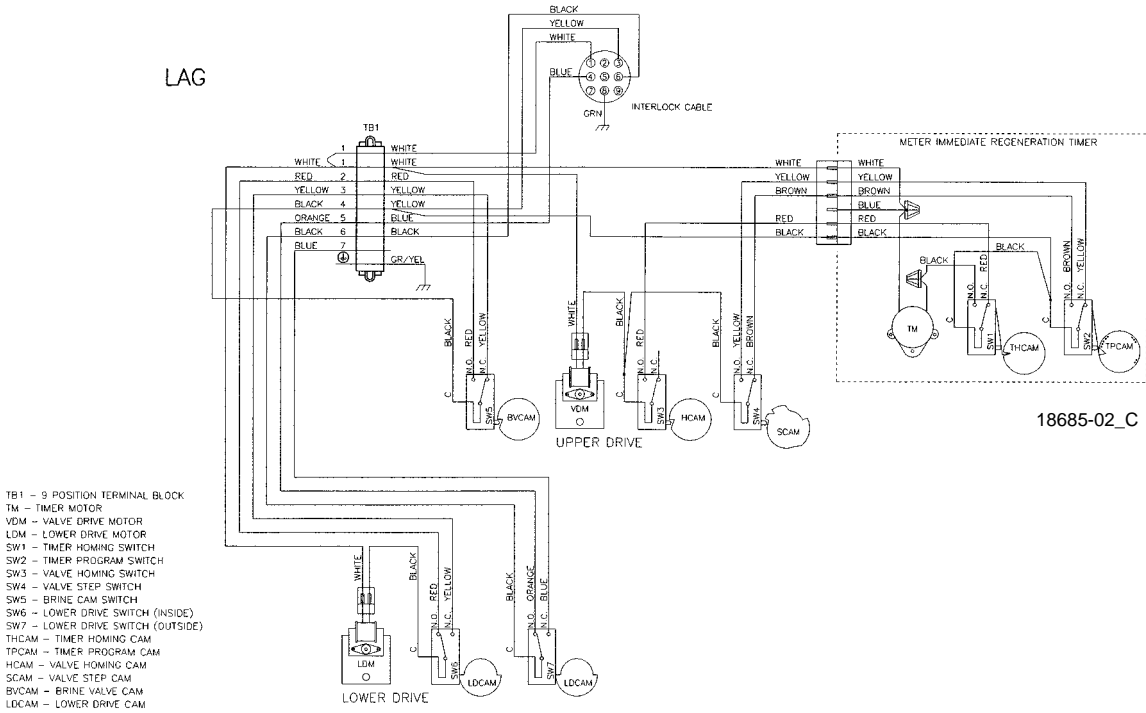

- TB1 - 9 POSITION TERMINAL BLOCK  
 TM - TIMER MOTOR  
 VDM - VALVE DRIVE MOTOR  
 LDM - LOWER DRIVE MOTOR  
 SW1 - TIMER HOMING SWITCH  
 SW2 - TIMER PROGRAM SWITCH  
 SW3 - VALVE HOMING SWITCH  
 SW4 - VALVE STEP SWITCH  
 SW5 - BRINE CAM SWITCH  
 SW6 - LOWER DRIVE SWITCH (INSIDE)  
 SW7 - LOWER DRIVE SWITCH (OUTSIDE)  
 THCAM - TIMER HOMING CAM  
 TPCAM - TIMER PROGRAM CAM  
 HCAM - VALVE HOMING CAM  
 SCAM - VALVE STEP CAM  
 BVCAM - BRINE VALVE CAM  
 LDCAM - LOWER DRIVE CAM

- NOTE:  
 1. TWO TANK INTERLOCKED, INDIVIDUAL METER, IMMEDIATE REGENERATION.  
 2. BOTH TANKS NORMALLY IN SERVICE. ONLY ONE TANK IN REGENERATION, THE OTHER REMAINS IN SERVICE.  
 3. VALVE SHOWN IN SERVICE.

## System #6-Series Regeneration Valve Wiring

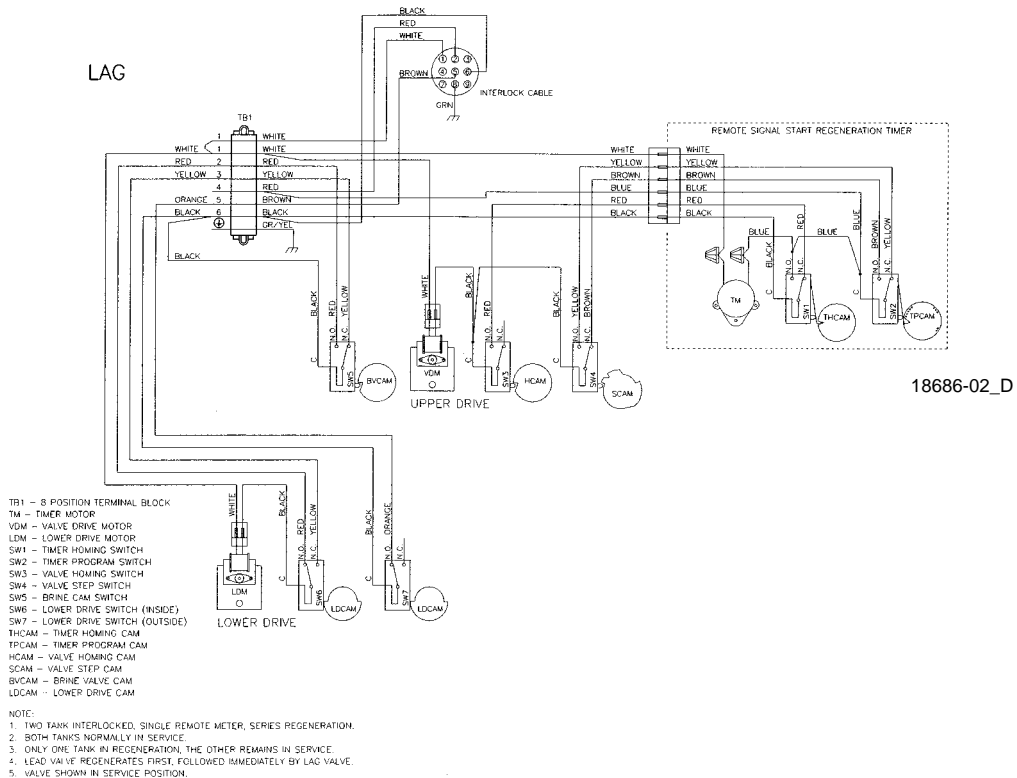
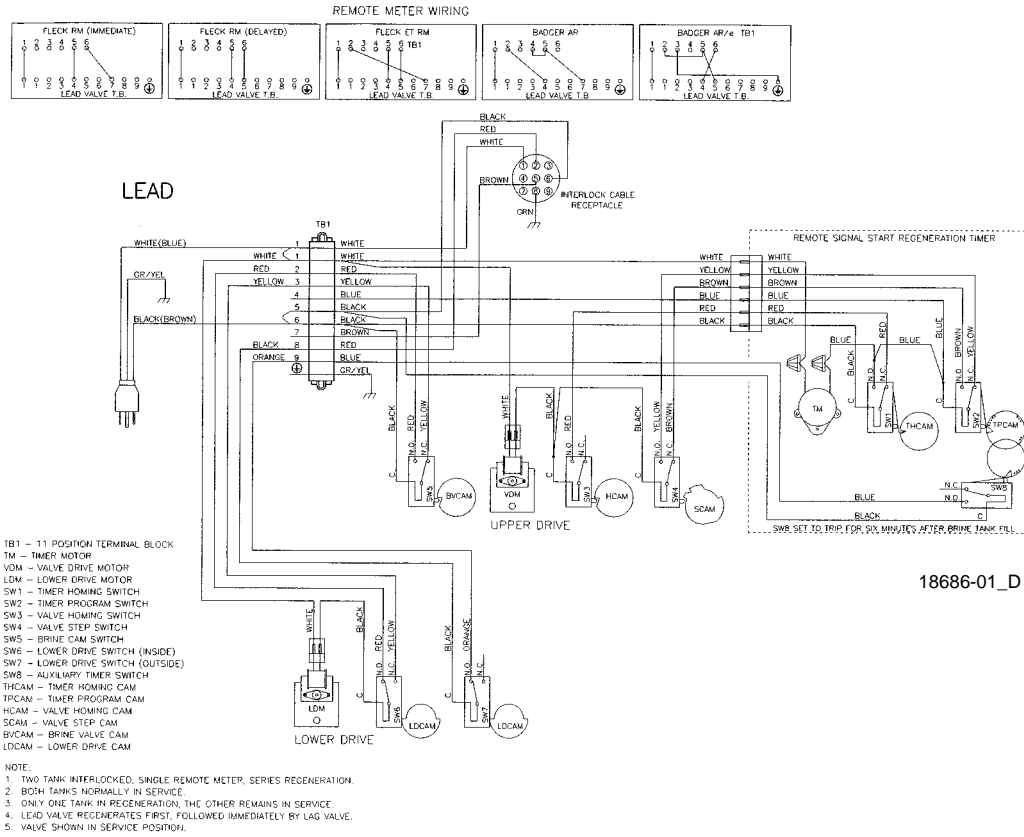

# MODEL 2900s

## System #7-Alternating Regeneration

### Valve Wiring

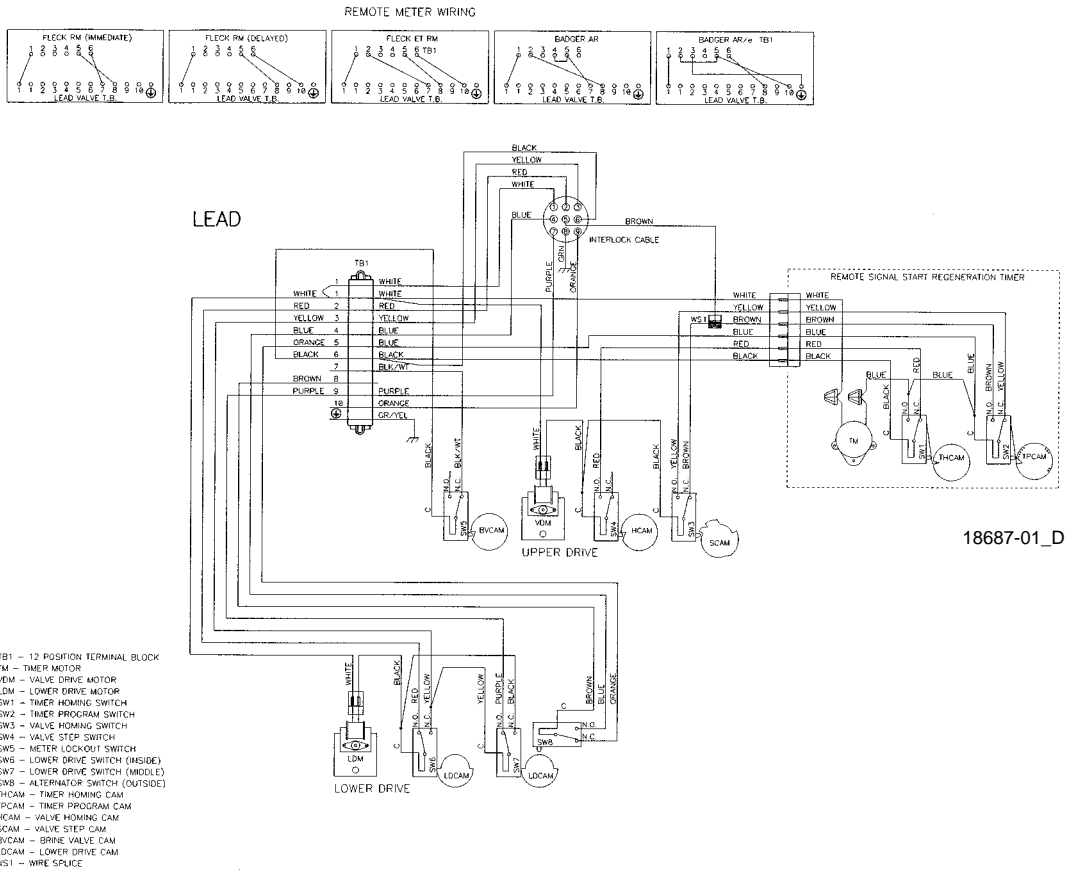

NOTE:  
 1. TWO TANK SINGLE REMOTE METER ALTERNATING REGENERATION.  
 2. ONLY ONE TANK IN SERVICE, THE OTHER IN REGENERATION OR STANDBY.  
 3. VALVE SHOWN IN SERVICE.

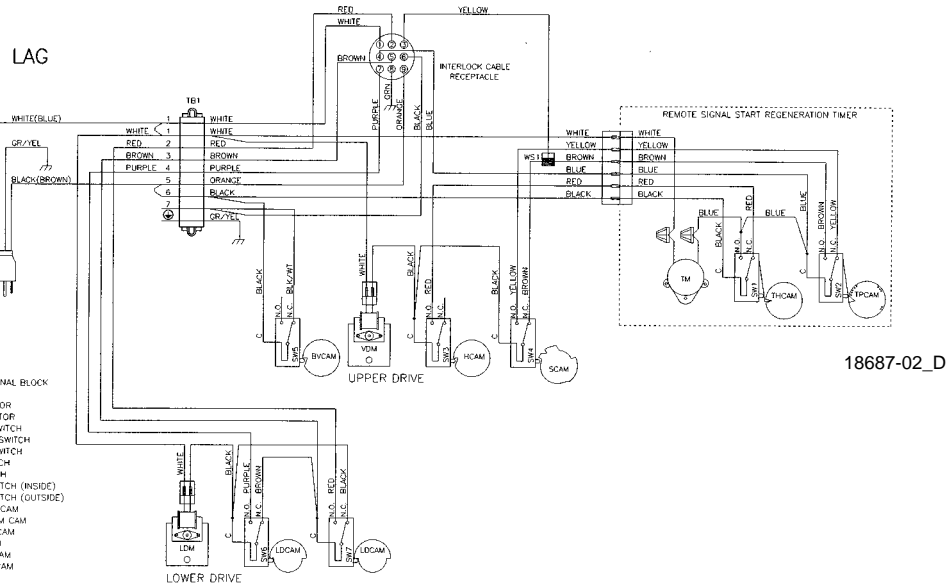

NOTE:  
 1. TWO TANK SINGLE REMOTE METER ALTERNATING REGENERATION.  
 2. ONLY ONE TANK IN SERVICE, THE OTHER IN REGENERATION OR STANDBY.  
 3. VALVE SHOWN IN STANDBY.

# MODEL 2900s

## System #7-Alternating Regeneration

### Multi-Valve System Valve Wiring

